

Strategies for Variability Reduction

R.J. MacKay and S.H. Steiner
University of Waterloo

RR-95-11 (NT)
October 1995
Revised June 1996

Strategies for Variability Reduction

R. Jock MacKay and Stefan H. Steiner
Department of Statistics and Actuarial Sciences
Institute for Improvement in Quality and Productivity
University of Waterloo
Waterloo, Ontario
Canada N2L 3G1

Abstract

An important goal of quality improvement in manufacturing is the reduction of variability in product characteristics. Producing more consistent output improves product performance and may reduce manufacturing costs. This article discusses and contrasts five generic variation reduction strategies that encompass all current methods. The five are: output inspection, feed-back control, reduction of variation in process inputs, feed-forward control, and process desensitization. Each strategy has distinct advantages and disadvantages and is only applicable in certain circumstances. The article compares and contrasts the strategies and provides practitioners guidance in choosing the most appropriate. An example from the automotive industry that illustrates the thought process necessary to choose appropriately is presented.

Introduction

An important goal of quality improvement in manufacturing is the reduction of variability in product characteristics. Producing more consistent output improves product performance and may reduce manufacturing costs.

The problem can be simply demonstrated. Suppose a process produces output with an important quality characteristic Y . See Figure 1. The current process performance, measured using an appropriate sampling scheme over a long enough period to capture most of the variation, is shown by the histogram. The goal is to reduce variability in Y while targeting the process at or near the nominal value. In this article, we focus on variation reduction, and implicitly assume either that any reduction obtained does not move the process mean significantly away from its target or that we can re-target the process mean without effecting the process variability.

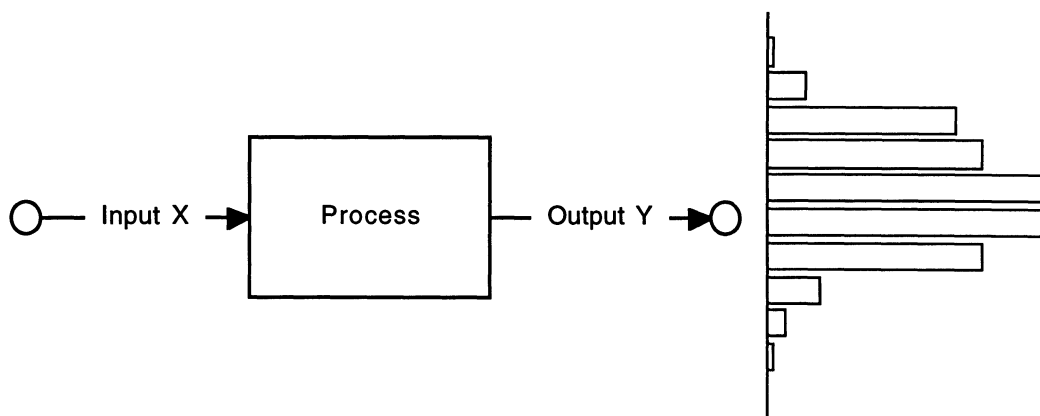

Figure 1: Process Diagram

Processes are managed using a control plan that describes how the process should be operated, and specifies the mechanisms through which the quality of a product will be monitored, controlled, and verified. In this context, reducing the process output variation requires either the modification of a current control plan or a change to the process itself. Changes to the method of operation corresponds to the idea of a living control plan as discussed in the Automotive Industry Action Group (AIAG) reference manual, *Advanced Product Quality Planning and Control Plan* referred to in the automotive industry quality standard, QS-9000. A living control plan is

constantly modified and improved as more information and insight on the process becomes available.

Reduction in output variation can be accomplished by changing the way the process operates in a number of different ways. In our experience, however, all variation reduction approaches can be classified into one of the following five generic strategies:

1. introducing or tightening output inspection;
2. introducing or improving feed-back control;
3. reducing variation in process inputs;
4. introducing or improving feed-forward control;
5. desensitizing the process to input variation;

Each of these five strategies is currently used in industry. A sixth strategy, which we do not assess in detail, is to discard all or part of the existing process and start again with a new method or technology. In some situations, this sixth strategy of replacing the existing process (or part of it) may be the only viable option. For example, we may purchase a new gauge to improve the accuracy of our measurements or use a new supplier whose products are of higher quality. However, in the spirit of continuous improvement, we believe that it is cost effective to consider strategies one through five first. In any case, strategy six could be considered an extreme example of strategy five, where the process is desensitized by changing the process radically.

All variation reduction strategies are dependent on the ability to measure precisely the process output Y and possibly input(s) X . As result, studies that examine the short term variability (gauge R&R), and long-term stability of the measurement system should be carried out prior to any variation reduction exercise. In this article, we assume that the measurements obtained are reliable, i.e. that the measurement system itself is not the major source of variation.

The choice of an effective strategy depends critically on knowledge of the existing process. Key aspects of this knowledge include stability, predictability, ability to adjust, and identification of the causes of the variation. The availability and cost of attaining this knowledge provides an important input to a decision on which process variation reduction strategy is most applicable.

The goal of the article is to contrast and compare each of the variation reduction strategies, highlighting the required process knowledge, potential costs, benefits and drawbacks of each method. We discuss each strategy in detail, providing information on how the strategy works and when it works. For each strategy we give simple examples and discuss more complex extensions. At the end of the article, this information is summarized in Table 1. The thought process required to choose judiciously is explored through a detailed example on a crankshaft machining process. We hope that this discussion will provide guidance to quality practitioners faced with a variation reduction problem.

Output Inspection

Output inspection is the simplest variation reduction strategy and is virtually always applicable. Assuming 100% effective 100% inspection, the variability is reduced by identifying and then scrapping or reworking all items that have values of Y beyond selected inspection limits. The more the limits are tightened, the greater is the reduction in variation. The effect of tightened inspection is illustrated in Figure 2. Imagine inspecting and sorting units based on whether they fall between the dashed lines shown, where any units falling outside the limits are either scrapped or reworked (and then re-inspected). Clearly, this selection of units reduces the overall variability in the product that is subsequently shipped.

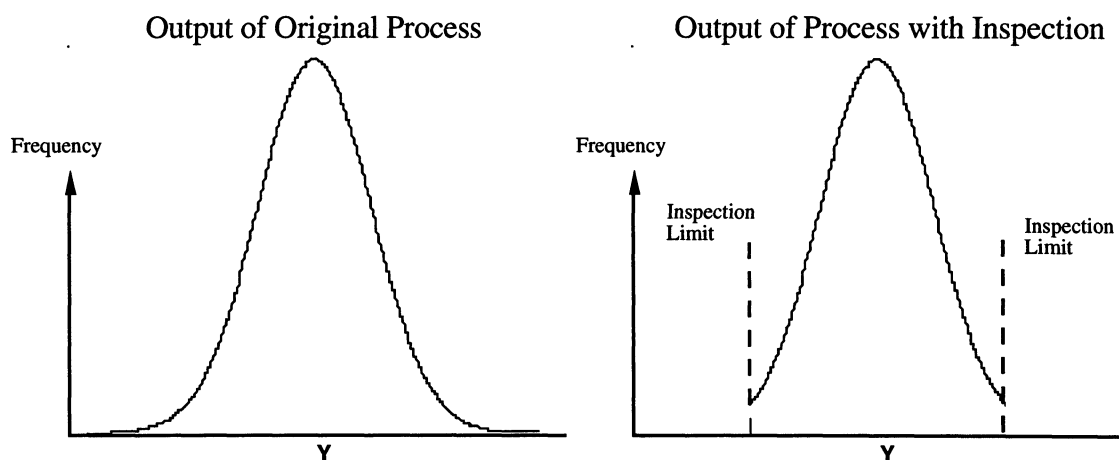

Figure 2: Output Inspection Example

Output inspection is very versatile. It can be successfully used in any situation where the output characteristic Y can be determined in advance of shipping the product to a customer. Output inspection is especially appropriate when the quality dimension is critical and the process produces only the occasional outlier or flier while all other units exhibit very little variation. For example, in the production of aluminum pistons, the diameter of each finished piston (as well as a number of other key characteristics) is measured by an automated gauge after the piston temperature is controlled. Pistons with large or small diameters are scrapped. In such a situation, the costs associated with 100% inspection, including installation and operation of the automated gauge, are warranted due to the high production volume and the critical nature of the product characteristic. Assuming no inspection error, the 100% inspection strategy has the advantage of being able to guarantee that no units with quality characteristic outside the inspection limits will be shipped to a customer.

Output inspection has a number of significant negative features. The cost of reducing variability by tightening the inspection limits may be very high due to increased rework and scrap costs and lost capacity. Also, the cost of inspection itself may be large if new gauging or additional labour is required. In addition, measurement or inspection errors will result in increased variability. As a result, given the propensity of people to make inspection errors, most successful applications use automated inspection.

One common modification of this strategy is inspection sampling where not every unit is measured. One approach is to define lots, where lots are accepted or rejected based on the quality of a sample taken from the lot. Accepted lots are shipped and rejected lots are 100% inspected or otherwise disposed. If we know that lot to lot variation is large and within lot variation is small, then inspection sampling is effective. Thus, using inspection sampling, variation may be reduced by redefining a lot, changing the inspection limits, or changing the lot acceptance criteria. Compared to 100% inspection, inspection costs are reduced. However, overall variability will not be reduced to the same degree. Note that if the process is stable, then partial inspection is a poor strategy. Deming (Chapter 15, 1986) showed that in this case either no or complete 100% inspection is optimal.

Feed-back Control

Feed-back control is a simple concept that may lead to complex procedures. The idea is to monitor the current output characteristic Y and to make adjustments to the process based on the observed output. By making appropriate adjustments, we compensate for changes in unidentified process inputs, thus reducing the variability in future values of Y . The effect of a simple feed-back control plan is illustrated in Figure 3. The panel on the left shows the output of the original process. The panel on the right shows the output of the same process when feed-back control is applied. The feed-back control mechanism involves re-targeting the process to zero whenever the process output exceeds the adjustment limit. The amount of adjustment is based on the last observed process output. Figure 3 demonstrates the resulting reduction in variability of Y .

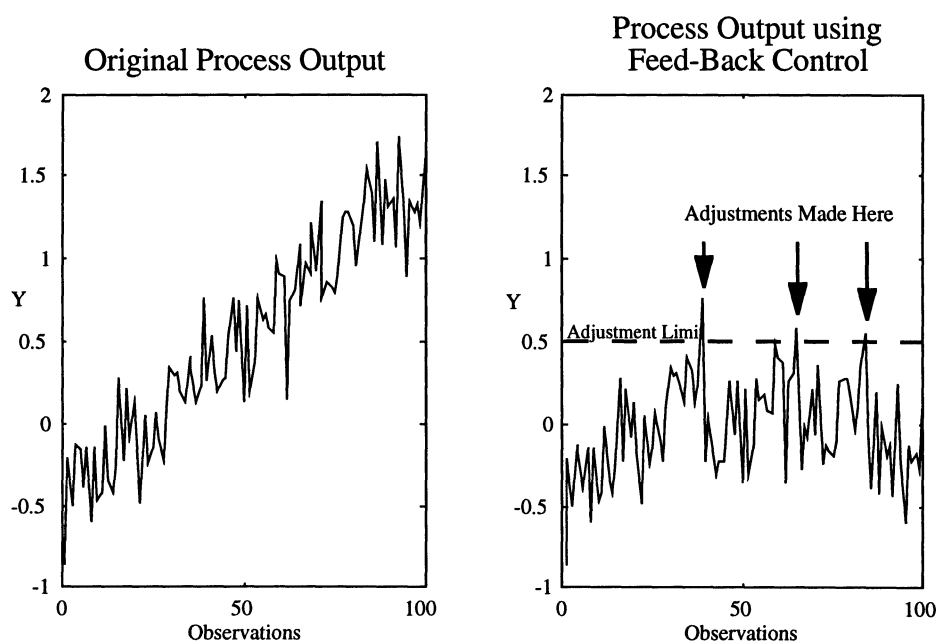

Figure 3: Feed-Back Control Example

Feed-back control can be successfully applied when three conditions are satisfied. First, the process must exhibit substantial structural variation (Joiner, 1994). Examples of structural variation include drift due to tool wear and stratification due to batch to batch variation. Second, there must be an adjustment procedure to re-target the process. Finally, the time to measure the output and adjust the process must be small relative to the rate of change of the process.

A feed-back control scheme is defined by its adjustment procedure that tell us when and how much to adjust, and its sampling frequency. Increased knowledge of the process behaviour may be used to improve the feed-back control scheme. For example, better knowledge of the nature of the structural variation can be used to change the sampling frequency or the adjustment rule.

As an example, feed-back control is used to reduce variation in the concentration of silicon in molten iron in a foundry. Iron is sampled at a fixed frequency from the output stream and the concentration of silicon is determined in the sample. Based on the observed concentrations, adjustments are made (upstream) to the feed rate of silicon in the melting process. Another common example is the use of procedures based on first-off measurements where, for example, a machining tool's set-up may be changed based on measurements taken on the first few products in a batch. Once a good set-up is achieved, no further process measurements are taken.

The major advantage of feed-back control is that it requires little knowledge of the causes of variation. Like output inspection, it only uses information obtained from the final product.

There are a number of drawbacks to feed-back control. A major danger is over-adjustment (tampering). If the process is stable (i.e. it does not exhibit structural variation), then adjusting on the basis of the output will lead to increased variability. This illustrated in the famous funnel experiment, see Deming, 1986 pp. 327-328. Another drawback is that the process measurements and adjustments may be expensive. Finally, due to the feed-back nature of the control, there is an inherent time delay. To identify when an adjustment is required, we must first observe some output values that are significantly different from the target value. Thus, feed-back control is always reactive.

There are many variations of feed-back control. See Tucker, Faltin, and Vander Wiel (1993) for further details. Specific examples include acceptance control charts (Duncan, 1986) and pre-control (Shainin and Shainin, 1989, Juran, Gryna, and Bingham, 1979). Most feed-back control systems use a function of recent output values, not just the last value, to determine if an adjustment is necessary. If the drift in Y is as regular as shown in Figure 3, we could also base

adjustments simply on the time or the number of units processed (or any other cheaply measured variable highly correlated with the output dimension Y).

Reduction of Variation in Process Inputs

As the saying goes “garbage in garbage out.” If there is a large amount of variation in process inputs, then it is difficult to produce consistent output. One improvement approach in this environment is to reduce the variability in one or more inputs. For ease of discussion, we assume, for the moment, a single important input X . See Figure 1. The input X may be a characteristic of raw materials or component parts, a changing environmental factor such as heat, or any other process input that changes over time. From the point of view of the process that produces X , the problem of reducing variability in X is analogous to reducing variation in Y and we have created a recursion in the problem definition.

The effect of reducing the variability in an input is illustrated by the variance transmission plots shown in Figure 4. In this example, most of the variation in Y is due to variation in the input X . As a result, if we reduce the variability in the input X as shown, the variability in the output Y will also be substantially reduced.

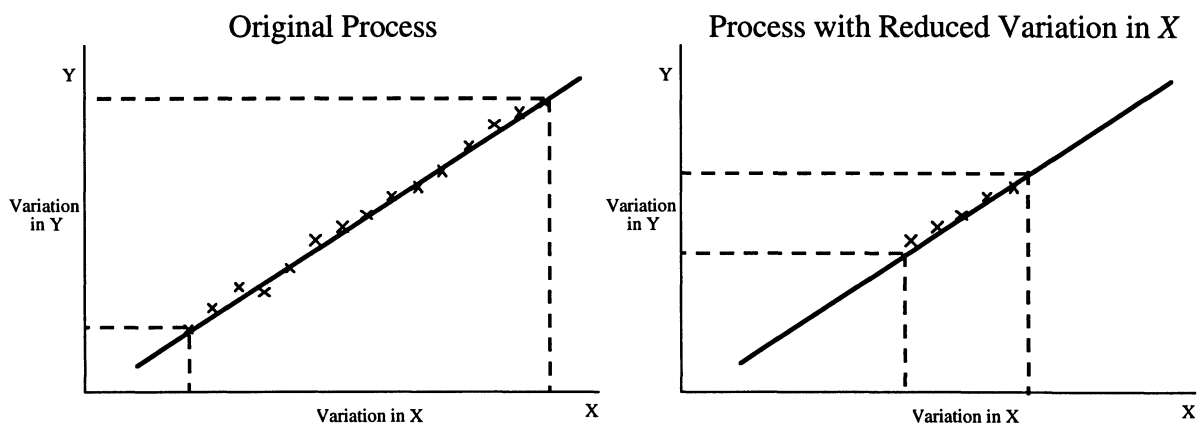

Figure 4: Variance Transmission between Input X and Output Y

There are three basic conditions necessary for this strategy to work. First, we must be able to identify an input X that has a causal influence on the output Y . Second, we must identify an X that is a major source of the variation in Y . Third, we must be able to reduce the variation in X .

There are many tools for discovering the identity of such an X . We may use observational studies such as control charts, multi-vari studies (Juran, Gryna, and Bingham, 1979) and regression, or we may use designed experiments which require an intervention in the process. It is important that the identified factor X is a significant factor influencing the variation in the output.

This approach is pro-active. The control of the process is moved upstream which may reduce cost and complexity, and less effort may be needed to monitor the process output Y . An example of this strategy occurred in the machining of the aluminum pistons described previously. A variation transmission study identified the piston diameter after an intermediate operation (X) as the major source of variation in final piston diameter. The variation of X was reduced by instituting improved operator instructions and training at the intermediate operation.

One difficulty with this strategy is that first we must identify an X , which is both an important contributor to the variation in Y and which is causally related. This may prove arduous and involve significant study costs. Second, reducing variability in X may be very difficult and/or costly. Third, tightened specifications on X moves the responsibility for control of the process upstream, and possibly outside the influence of local management.

Figure 4 shows a continuously varying input X . However, in many cases X is discrete. For example, X could represent multiple suppliers or multiple machines in parallel processing operations. In this case, reducing variation in X could be accomplished by reducing the number of suppliers or establishing procedures to reduce differences among the suppliers. Also, in general, the situation where a number of important X variables can be identified should be considered since in typical applications there are many inputs that are sources of variation. With any input factor that satisfies the three given conditions, reducing the variation in that input is a viable output variation reduction strategy. However, the resulting reduction in variation of the output Y depends on how strong a source of variation X is and how successfully we can reduce its variability.

Fortunately, based on the Pareto principle, we can usually focus on only the one or two most important X factors since they typically contribute the majority of variation in Y .

Feed-forward Control

Using feed-forward control, we adjust the process in response to measurements made on an input X , anticipating the effect on the output Y . If the measured value of X provides a good prediction of the corresponding output Y , feed-forward control can reduce variation in Y by adjusting the process to compensate for different X values. Figure 5 demonstrates the effect of adjusting Y based on knowledge of X and the relationship between X and Y .

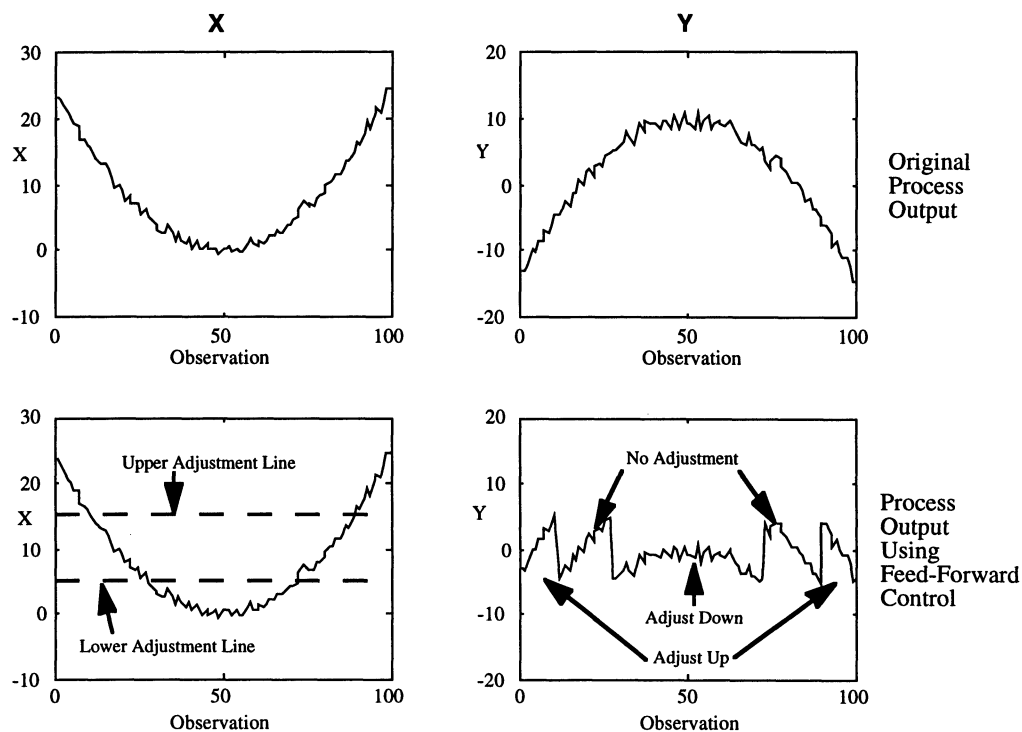

Figure 5: Feed-forward Control Example

Feed-forward control works under restrictive conditions. First, we must identify an X that is an important source of variation in Y . Second, the relationship between X and Y must be well known and stable over time. Third, we must be able to measure X in a timely way. Finally, there must be a way to adjust the process to compensate for the changes in X .

Feed-forward control can be very effective if the above conditions are satisfied. A simple example is the use of set-up procedures based on the properties of the raw materials. Feed-forward control is an attractive alternative since it is proactive, and because it is not necessary to measure the output Y .

There are substantial costs and risks associated with feed-forward control. Costs arise because we need to determine the relationship between X and Y , measure X , and repeatedly adjust the process when appropriate. As with feed-back control, there is a danger of over adjustment if there is a measurement problem with X , or if the relationship between X and Y is not well understood and stable. In addition, repeated process adjustment may be impractical or costly and may introduce undesired side effects.

Applications of feed-forward control are not always easily identified. Consider selective fitting, the technique of sorting and matching component parts to get good assemblies. Selective fitting has been used to reduce variation in clearance between pistons and cylinder block bore walls by matching piston and bore diameters. This is feed-forward control since we measure the dimensions (X) of the pistons and bores and use that knowledge to adapt the matching process. Note that this adds complexity to the assembly process.

Process Desensitization

Desensitization of the process aims to reduce variability by making the process more robust to the variability in process inputs. This is also called parameter design as discussed by Taguchi (1985) and Nair (1992). Desensitizing the process works by identifying and exploiting interactions between important varying inputs X and other normally fixed process parameters such as machine settings. In this context Taguchi calls X a noise factor or variable. Figure 6 demonstrates how modifying the relationship between Y and X by changing other process parameters results in less variation in Y over the same range of variability in X .

Typically the settings of the control parameters that yield a more robust process are identified through a designed experiment which uses both X and selected process parameters

(called control parameters) in the experiment. The experiment must be designed so that interactions between X and the control parameters can be identified.

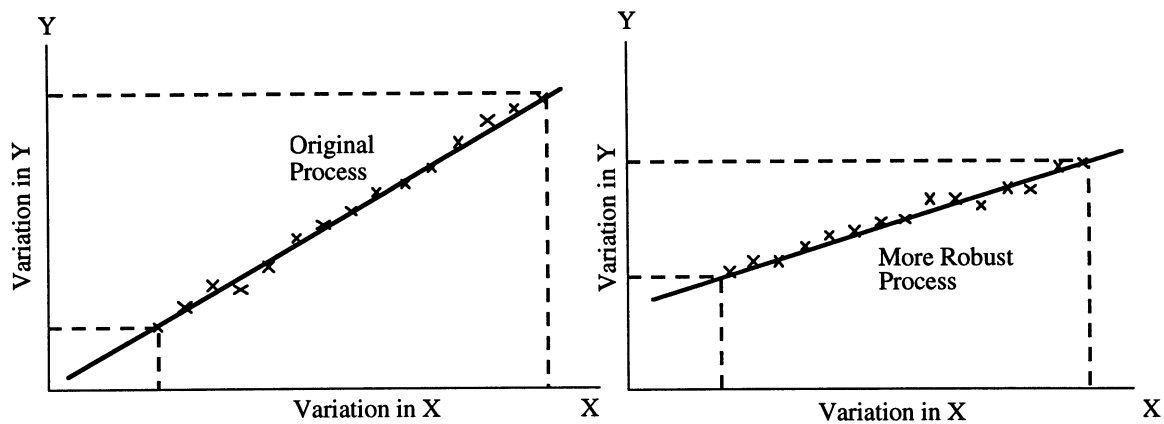

Figure 6: Desensitizing the Process Example

Process desensitization is a desirable strategy since once it is complete, no further action is required. Taguchi (1985) cites several examples, including the famous Ina tile case. Another example involved the reduction of variation of the sulfur concentration (Y) in molten iron where X was the uncontrollable amount of sulfur in the scrap iron being melted. It was known that Y was highly dependent on the amount of sulfur (X) in the scrap iron. An experiment identified a new way to run the desulfurization process that reduced this dependency and hence reduced the variability of Y .

It is difficult to predict when desensitizing the process will work. This is one of its great weaknesses. Also, making a process more robust requires a great deal of process knowledge. Determining appropriate settings of the control parameters usually requires expensive designed experiments that may fail to determine process settings that lead to improvement. Also, the new process settings may lead to extra costs.

In theory, making a process more robust can be accomplished without any knowledge of the factor X , even its identity. Taguchi recommends identifying X (the noise factor) and then conducting an inner-outer array experiment in which X is controlled. An alternative is to define an experimental run as the operation of the process over a period of time sufficiently long to allow the unknown X to vary substantially. The process variability is measured over each run and is then

used as the response in the analysis of the experiment. However, without knowing X , we run a significant risk of determining a more robust setting that is only better under the limited operating conditions used in the experiment. It is also more difficult to identify process parameters that may be used to reduce the variation when X is not identified. Process desensitization without knowledge of X is illustrated by the speedometer cable example (Quality Engineering Using Design of Experiments, 1985, p. 367). The goal was the manufacture of speedometer cables that had very little variation in the shrinkage along the length of the cable. An experiment was designed that varied process factors. Based on the results of the designed experiment new process settings were determined that resulted in less shrinkage variation, however, the identity of a cause for variation was not reported.

Choosing A Strategy - An Example

In any application, a decision must be made as to which strategy or combination of strategies should be used. To demonstrate the thought process required, we consider an example from the machining of crankshafts.

Journal diameter is a key product characteristic on machined crankshafts. To keep the discussion simple, we consider only one diameter of the several that are measured. Y is the diameter of the shipped product. The machining process at the start of the variation reduction effort, with respect to the diameter, called the initial process, is illustrated in Figure 7.

The raw castings, identified by hour, date of casting and mold number, were processed by one of four grinders and subsequently automatically 100% inspected. All crankshafts that did not conform to the after-grinder specification were either scrapped or reworked. All in-specification parts were subsequently lapped to improve the surface finish. After the lapping operation, all output was again automatically 100% inspected at the final gauge with parts not conforming to the final product specifications yielding scrap or rework. At any time, if an operator noticed a significant number of rejects due to small or large journal diameters at either gauge, he or she asked for an adjustment of all the grinders. Also, periodically, if the final output quality was deemed

poor, the inspection limits at the intermediate gauge were changed. Thus, initially the process was controlled using a combination of inspection and feed-back control.

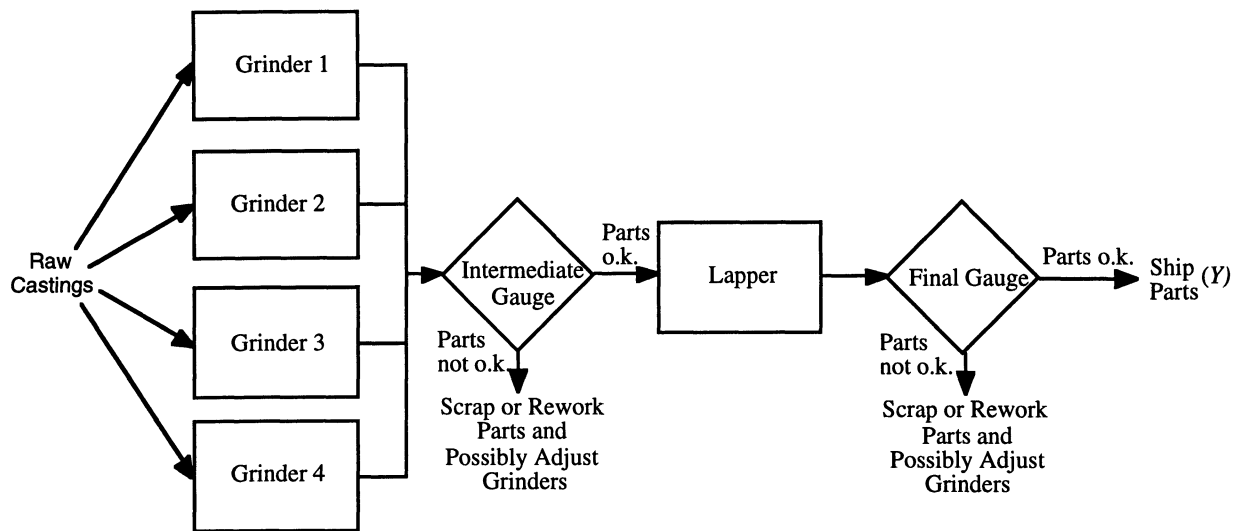

Figure 7: Crankshaft Production Process

The initial process had a process capability $C_{pk} \approx 1$ which was considered too low. As well, there was an unacceptably high level of scrap/rework. The objective was to reduce long term variation in the journal diameters of finished crankshafts and decrease costs. The question of interest was how to select an appropriate variation reduction strategy.

A required preliminary step in our investigation was studying the measurement systems utilized. This is fundamental since we base much of our process knowledge and control decisions on measurements, and indeed the whole impetus for conducting this variation reduction exercise is based on the measurements. To determine the quality of the measurement systems both the short term variability and the stability of both the gauge measurements were examined. A gauge R&R study (Measurement Systems Analysis, 1990) showed that both gauges were capable in the short term; in other words, the amount the variation introduced by the measurement system was small compared with the typical process variation. A stability study of the gauges where a master part was measured every 2 hours, however, showed that the intermediate gauge was unstable. This was fixed by performing extensive maintenance on the intermediate gauge. The measurements on the master part also identified a calibration problem since there was a systematic difference between the measurements obtained with the two gauges. This problem was alleviated by re-targeting the

intermediate gauge. Based on these studies, an ongoing program was established to ensure the measurement systems remain stable, capable and calibrated. Once confidence in the measurement system was established, we turned to the goal of variation reduction.

The simplest approach, since it does not require any additional process information, was tightening the inspection limits at the final gauge. This approach could be easily implemented since inspection was already performed. The consequence would be reduced variation in Y , but also an increase in scrap and rework and lost capacity, which in this case was considered too expensive.

Determining whether any of the other strategies were feasible required more information about the process. The first step was to determine current process performance in terms of stability and structural variation of the output measurement. This required monitoring process performance at the final gauge. To gain as much process information as possible we used measurements from all units even those that were rejected by the inspection scheme. \bar{X} and R control charts based on five consecutive parts measured every two hours at the final gauge are shown in Figure 8. The control charts show that the process was stable and did not appear to exhibit structural variation over time. As a result, feed-back control did not appear to be a viable strategy. At this point, a more extensive study, for example, one that tracks output from every crankshaft could be considered, since additional study may show that exploitable structural variation does exist. However, this analysis was postponed to pursue more promising avenues.

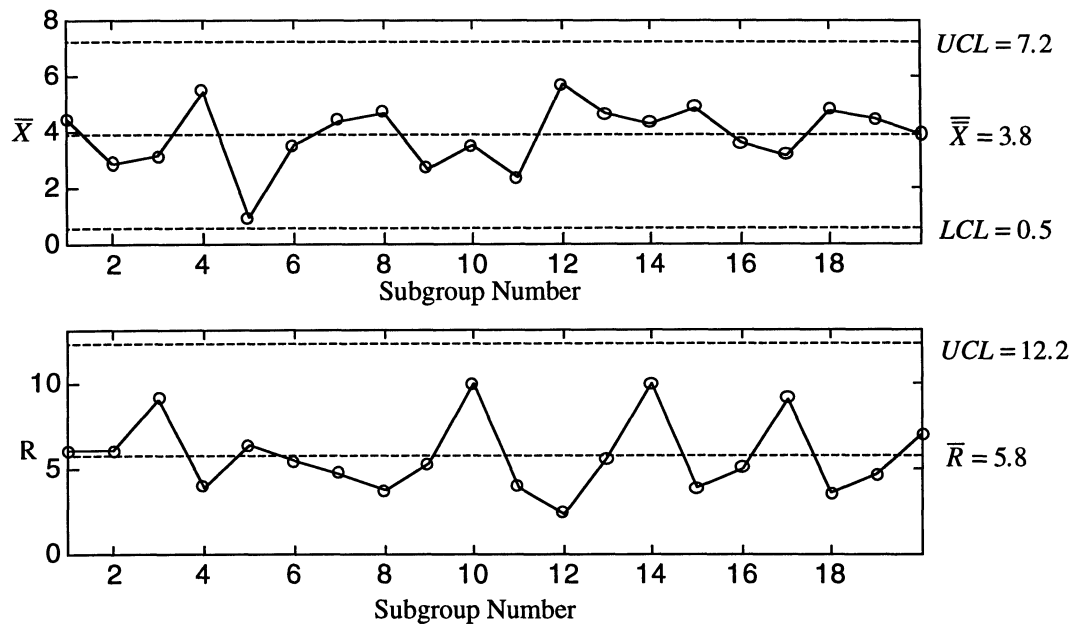

Figure 8: \bar{X} and R Control Charts of Final Crankshaft Data

The remaining variation reduction strategies require the identification of an input X that is an important source of variability in the final journal diameters. A study was conducted where parts were sampled from each grinder and followed through the lapper step to see how the grinders and measurements at the intermediate gauge were related to the final journal diameters. In the study, six sample parts were taken from each of the four grinders. Figure 9 shows a scatter plot of all 24 pairs of before and after lapper journal diameter measurements. Clearly there was a very strong relationship between before-lapper diameter and the final diameter (Y). Thus, we concluded that the before-lapper journal diameter is an X , since the variability in the before lapper diameter appeared to cause the majority of the variability in final journal diameter. Note that we also determined that the variability caused by the lapper itself is relatively small although it transmits the variability in X . Thus, reducing the variation added by the lapping operation was not considered a priority.

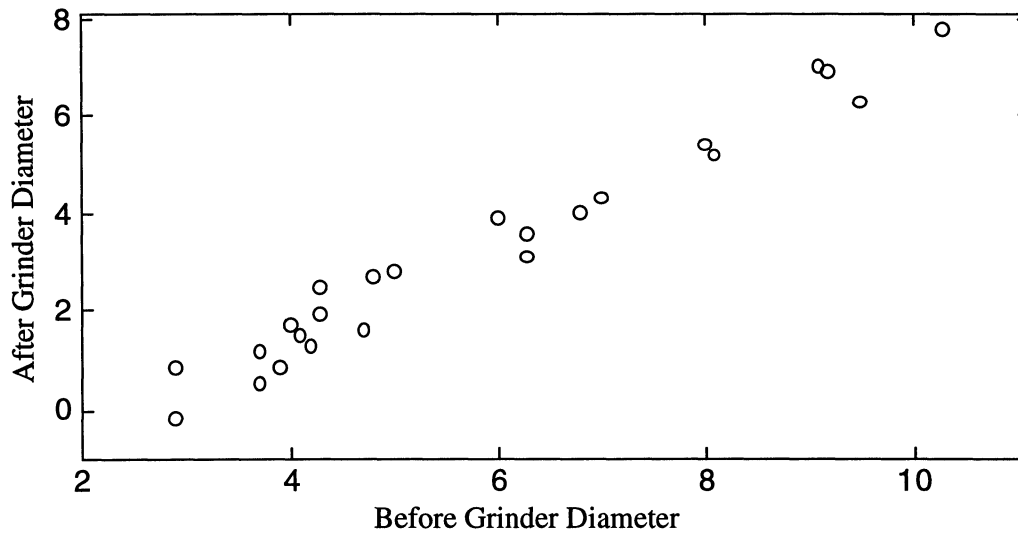

Figure 9: Scatter plot of Before Versus after Lapper Journal Diameters

The remaining three strategies were then considered. A version of feed-forward control would be the use of a “smart” lapper that would measure the incoming journal diameter for each crankshaft and change the lapping time accordingly. Note, however, that the major purpose of the lapper is to improve surface finish, so this scheme would involve a change in function for the lapper. Also, this strategy would likely require greater lapping times and result in a bottleneck at the lapping operation. Thus, feed-forward control was rejected due to high cost. The strategy of desensitizing the process to the variation in after-grind diameter was briefly considered and also rejected because there were no process parameters in the lapping operation that could be feasibly be changed to yield a process more robust to variation in incoming journal diameters. This elimination process left reduction in the variation of journal diameters prior to lapping (reducing variation in X) as the only feasible strategy.

To reduce the variation in X , we again considered each of the five generic strategies. Tightening the inspection criterion, this time at the intermediate gauge, was the first strategy considered. This would yield reduced variability in parts sent to the lapper. However, tighter inspection on X was rejected since the increase in scrap and reduced yield was deemed too expensive.

Feed-back control was also a possibility, but informal monitoring of X at the intermediate gauge failed to show any structural variation due to time, and further study at this point was again unwarranted since more promising approaches were present.

At this stage, we needed further information about what was causing the variation in X . Our previous study that sampled parts from different grinders and followed them through the process provided some valuable information. Using the results of that study, we investigated the influence of the different grinders. Table 1 shows the results of an analysis of variance (ANOVA) to study the effect of different grinders on the final diameter. The average value of the after grinder diameters were 6.4, 2.1, 1.0 and 3.2 respectively with a standard error of 0.41. Clearly, between grinder variation was a significant contributor to the variation in X . As a result, an input factor that caused a significant amount of the variation in X was the grinder number. We denoted this factor X_2 . Notice that X_2 was discrete with four different realizations.

Table 1: Analysis of Variance Table for Crankshaft Example

Source	Degrees of Freedom	Sum of Squares	Mean Square	F	p
Grinder	3	98.38	32.79	32.56	0.000
Error	20	20.14	1.01		
Total	23	118.52			

Having identified X_2 , one possible variation reduction strategy was to use feed-forward control. In the initial process, feed-forward based on X_2 was not possible since the grinder used was not recorded. However a simple process change would make it potentially feasible. For example, we could have changed the transfer process between the grinders and the lappers so that the lapper worked sequentially on a batch of crankshafts from a single grinder. Then feed-forward control would be possible because the lapper could be set to remove more material from batches ground by a grinder that typically yielded larger incoming diameters. For this feed-forward control scheme an estimate of the average diameters that would result from each grinder would be needed. A potential problem with this approach was that to ensure the lapper was compensating correctly, each grinder's average output diameter must either stay constant over time, or occasionally be re-

estimated. This feed-forward strategy was similar to the one previously discussed and was also rejected since it would lead to a bottleneck at the lapping operation. Desensitizing the process to the variation in grinder targets was also rejected because, as mentioned previously, there were no process parameters in the lapping operation that could be feasibly be changed.

This left reducing the differences between the grinders (reducing variation in X_2) as the logical alternative. Based on Table 1, we anticipated that removing the between grinder variation would reduce the variation in the before lapping diameter from approximately 5.2 to 1.0. This was accomplished by realigning the four grinders so that their output was targeted to the same nominal mean value. The results of implementing these changes in the process showed a decrease in the variation of the final diameters, and a substantial reduction in the amount of scrap and rework generated by the process at both the intermediate and final inspections. The intermediate and final inspections were retained to monitor the success of the new control plan and to protect against poor quality.

This example presents a successful application of variation reduction and illustrates the thought process followed. However, reduction in variation itself should be an ongoing process. For example, based on our experience with grinders we suspect that the average output value of each grinder will drift over time. This implies that the implemented variation reduction strategy will only be effective in the short term. This anticipated structural variation in X was not evident previously since when measuring X the output from the different grinders was mixed together and the drift is probably fairly slow. This suggests that by plotting the after grinder diameter for each of the grinders separately, over a longer time, structural variation may become evident. These plots can be obtained by either changing the intermediate gauge into four separate gauges one for each grinder, or keeping track of which grinder was used for each part. If this structural variation exists, we anticipate that keeping the grinders aligned can be accomplished using feed-back control on the diameter after grinding. Identifying the exact nature of this feed-back control requires more information and is currently the object of further study. Determining the best feed-back control scheme will require an understanding of the costs associated with re-targeting, grinder maintenance, downtime, etc. and an understanding of the variability caused by the grinder itself.

In this example, there are also many other process changes that potentially could lead to variation reduction. At each iteration of our analysis we tried to focus on the major source of variability since it provides the greatest potential for improvement. However, in subsequent variation reduction exercises different sources of variation will be most important and different strategies will likely be most appropriate.

Summary and Conclusions

This article compares and contrasts five variation reduction techniques. We believe these five techniques either singly or in combination encompass all possible variation reduction methods. The goal of the article is to describe and explain the various methods and to aid the practitioner in making a judicious choice of technique. The process knowledge requirements and potential risks of the different variation reduction methods are summarized in Table 1. By keeping in mind the various strategies and their strengths and weaknesses, a practitioner will be able to make better decisions regarding process information that should be obtained and how best to improve the process.

Choosing an appropriate variation reduction strategy is not a linear process. At each stage there are many options and there is no recipe. In each variation reduction exercise we try to learn enough about our process so that the feasible strategies are determined. However, often it is the quality of our study that determines how much useful process knowledge we obtain. A study can fail to identify a process characteristic, such as structural variation, either because the characteristic is not present, or because the study is flawed. For example, in the crankshaft example, based on the current data no structural pattern in the after grinding diameters is apparent, but structural variation may be evident if we look at the output of each grinder separately. This means that as we obtain more process knowledge we may be led to designing different studies. Also, variation reduction is an ongoing process with each subsequent iteration attempting to further reduce the variation.

Another potential problem, in practice, is that the current process control strategy, such as feed-back or feed-forward control, masks the operation of the actual process and may make it

difficult to determine an appropriate variation reduction strategy. For more information on overcoming this difficulty and a good review of process control strategies see Box and Kramer (1992).

For ease of discussion, this article has focused on the applications with only single quality characteristic Y . In most practical applications a product would have multiple critical characteristics that must all be controlled simultaneously. In that case, reducing the variation in the output is a more difficult problem, since we do not want to reduce the variation in one characteristic only to see the variation in some other characteristic increase. The complications introduced by considering multiple quality characteristic simultaneously is worthy of further study.

Table 1: Summary of Information and Process Requirements of the Five Generic Variability Reduction Strategies

Variability Reduction Strategy	Information and Process Requirements	Potential Risks
Introducing or Improving Output Inspection	measurement on Y	scrap/rework/inspection costs inspection errors loss of capacity
Introducing or Improving Feed-Back Control	measurement on Y process targeting procedure stable structural variation in Y	measurement time lag over-adjustment
Reducing Variation in X	identity of X measurement on X	not true X increased cost of inputs
Introducing or Improving Feed-Forward Control	identity of X measurement on X process re-targeting procedure stable $Y = f(X)$ relationship	not true X over-adjustment $Y = f(X)$ relationship unstable
Desensitizing the Process	identify robust process settings feasible robust process settings identity of X is useful	may work only in experiment new process settings may be more expensive

Acknowledgments

The authors would like to thank Donald Holmes for valuable comments that lead to a substantial improvement in the presentation of this material. This research was supported, in part, by the Natural Sciences and Engineering Research Council of Canada.

References

- Advanced Product Quality Planning and Control Plan: Reference Manual*, (1994), Automotive Industry Action Group.
- Box, G., Kramer, T. (1992), "Statistical Process Monitoring and Feedback Adjustment – A Discussion," with discussion, *Technometrics*, 34, 251-285.
- Deming, W. E. (1982), "Out of the Crisis," MIT Center for Advanced Engineering Study.
- Duncan, A.J. (1986), *Quality Control and Industrial Statistics* (5th ed.), Homewood, IL: Richard D. Irwin.
- Joiner B.L. (1994), "Fourth Generation Management: The New Business Consciousness," McGraw-Hill, New York.
- Juran, J.M., Gryna, F.M., Bingham, R.S., (eds.) (1979), *Quality Control Handbook*, Third Edition, McGraw Hill, New York.
- Measurement Systems Analysis*, (1990), Automotive Industry Action Group.
- Nair, V.N. (1992), "Taguchi's Parameter Design - A Panel Discussion," editor, *Technometrics*, Vol. 34, 127-162.
- Quality Engineering Using Design of Experiments, The Third Supplier Symposium on Taguchi Methods, American Supplier Institute, 1985
- Shainin D., Shainin, P. (1989), "Pre-Control versus \bar{X} and R charting: continuous or immediate quality improvement?," *Quality Engineering*, Vol. 1, 419-429.
- Taguchi, G., Wu, Y. (1985), *Introduction to Off-line Quality Control*, Central Japan Quality Control Association.
- Tucker, W.T., Faltin, F.W., Vander Wiel, S.A. (1993), "Algorithm Statistical Process Control: An Elaboration," *Technometrics*, Vol. 35, 363-375.

RR-95-11
Strategies for Variability Reduction
R. Jock MacKay and Stefan Steiner

This report was revised and reprinted as requested by Stefan Steiner.

Attached are the copies of the original report dated October 1995 that were in the Library. The **REVISED** reports dated June 1996 are now in the Library.

Also attached is the master copy of the original report. The **REVISED** master copy is in the filing cabinet in the appropriate file folder.

Strategies for Variability Reduction

R. Jock MacKay and Stefan Steiner
University of Waterloo

I.I.Q.P. Research Report

RR-95-11

October 1995

*Revised
June 24/96*

Strategies for Variability Reduction

R. Jock MacKay and Stefan H. Steiner
Department of Statistics and Actuarial Sciences
Institute for Improvement in Quality and Productivity
University of Waterloo
Waterloo, Ontario
Canada N2L 3G1

Abstract

An important goal of quality improvement in manufacturing is the reduction of variability in characteristics of process output. Producing more consistent output improves product performance and may reduce manufacturing costs. This article discusses and contrasts five generic variation reduction techniques that encompass all current methods. The five approaches are: final product inspection, feed-back control, reduction of variation in process inputs, feed-forward control, and process desensitization. Each technique has distinct advantages and disadvantages and is only applicable in certain circumstances. The article discusses the various techniques and provides practitioners guidance in choosing the most appropriate approach. Two examples that illustrate the thought process necessary to choose appropriately are given.

Introduction

An important goal of quality improvement in manufacturing is the reduction of variability in characteristics of process output. Producing more consistent output improves product performance and may reduce manufacturing costs.

The problem can be simply demonstrated. Suppose a process produces output with an important quality characteristic Y . See Figure 1. The current process performance, measured over a long enough period to be stable, is shown by the histogram. The goal is to reduce variability in Y while targeting the process at or near the nominal value. In this article, we focus on variation reduction, and implicitly assume either that any reduction obtained does not move the process mean significantly away from its target or that we can re-target the process mean without effecting the process variability. In this way, reducing the variability in Y will improve the process capability.

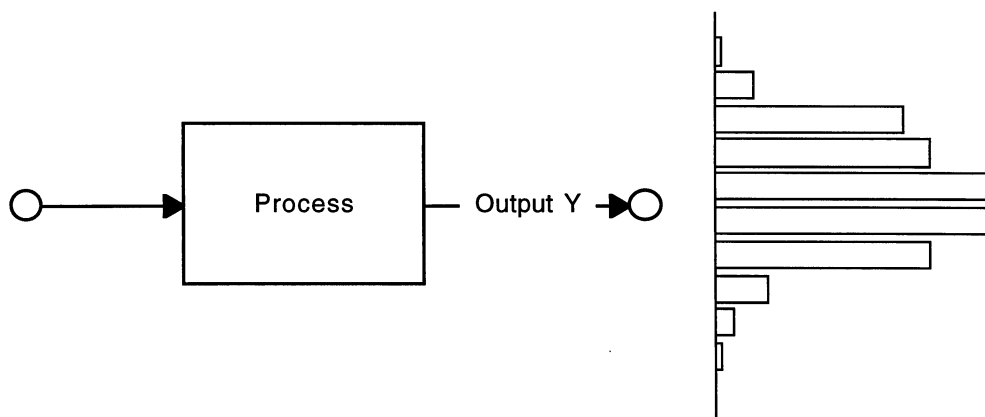

Figure 1: Process Diagram

Reduction in variation can be accomplished in a number of ways. In our experience, all approaches can be classified into one of five generic strategies:

1. final product inspection;
2. feed-back control;
3. reduction of variation in process inputs;
4. feed-forward control;

5. process desensitization.

All five strategies are currently used in industry. Every process is managed using one, or more usually, a combination of strategies 1 to 4, whereas strategy 5 is solely an improvement technique. Reducing the variation inherent in an existing process requires the modification of a current strategy or the adoption of a new one. No reduction in variation can be achieved without changing either the process or how it is managed. Process monitoring (e.g. control charts) on either outputs or inputs may lead to understanding of how the process operates but will not, by itself, result in variation reduction.

This corresponds to the idea of a living control plan as discussed in the AIAG reference manual, *Advanced Product Quality Planning and Control Plan*. This manual is referenced in the automotive industry quality standard, QS-9000. A control plan specifies the mechanisms through which the quality of a product will be monitored, controlled, and verified. A living control plan is constantly modified and improved as more information on the process becomes available.

The goal of this article is to contrast and compare each of the variation reduction strategies, highlighting the required process knowledge, potential costs and benefits of each method. Each strategy has potential advantages and drawbacks and is applicable only in certain circumstances. The choice of an effective strategy depends critically on knowledge of the existing process. Key issues include stability, predictability, ability to adjust, and identification of the causes of the variation. The availability and cost of attaining this knowledge provides a key input to a decision on which process variation reduction strategy is most applicable. We hope that this discussion will provide guidance to quality practitioners faced with a variation reduction problem.

Final Product Inspection

Final product inspection is the simplest variation reduction strategy and is virtually always applicable. Variability is reduced by identifying and then scrapping or reworking all items that have values of Y beyond selected inspection limits. The more the limits are tightened, the greater is the reduction in variation. The effect of tightened inspection is illustrated in Figure 2. Imagine

inspecting and sorting units based on whether they fall between the dashed lines shown, where any units falling outside the limits are either scrapped or reworked (and then re-inspected). Clearly, this selection of units reduces the overall variability in the process output that is subsequently shipped.

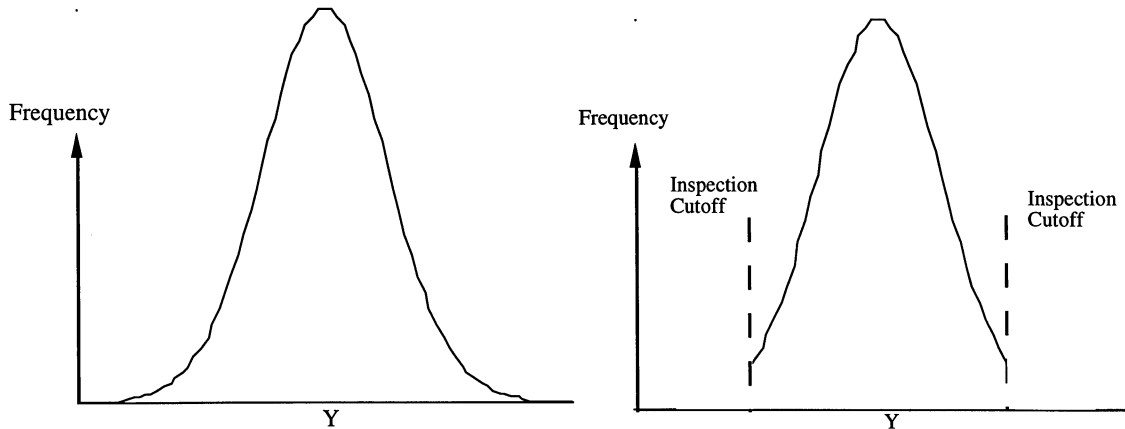

Figure 2: Final Product Inspection Strategy

Final product inspection is very versatile. It can be successfully used in any situation where the output characteristic Y can be determined in advance of shipping the product to a customer. Final product inspection is especially appropriate when the quality dimension is critical and the process produces only the occasional outlier or flier while all other units exhibit very little variation. For example, in the production of aluminum pistons, the diameter of each finished piston (as well as a number of other key characteristics) is measured by an automated gauge after the piston temperature is controlled. Pistons with large or small diameters are scrapped. In such a situation, the costs associated with 100% inspection, including installation and operation of the automated gauge, are warranted due to the high production volume and the critical nature of the product characteristic. Assuming no inspection error, the 100% inspection strategy has the advantage of being able to guarantee that no units with quality characteristic outside the inspection limits will be shipped to a customer.

Final product inspection has a number of significant negative features. The cost of reducing variability by tightening the inspection limits may be very high due to increased rework and scrap costs and lost capacity. Also, the cost of inspection itself may be large if new gauging or

additional labour is required. Measurement or inspection errors will result in increased variability. As a result, given the propensity of people to make inspection errors, most successful applications use automated inspection. As shown in Figure 1, the resultant quality of many of the units passed through our inspection procedure may be just barely inside the cutoff values. As a result, from a loss function perspective (Taguchi, 1986), inspection may be a poor approach since the output may be only marginally better after the inspection procedure. Finally, inspection is applicable to processes with continuous flows only if the production is divided into batches.

One common modification of this strategy is inspection sampling where not every unit is measured. This requires the definition of a lot. Lots are accepted or rejected based on the quality of a sample taken from the lot. Accepted lots are shipped and rejected lots are 100% inspected or otherwise disposed. If we know that lot to lot variation is large and within lot variation is small, then inspection sampling is effective. Thus, using inspection sampling, variation may be reduced by redefining a lot, changing the acceptance criteria, or changing the inspection limits. Compared to 100% inspection, inspection costs are reduced. However, overall variability will not be reduced to the same degree. Note that if the process is stable, then partial inspection is a poor strategy. Deming (Chapter 15, 1986) showed that in this case either no or complete 100% inspection is optimal.

Feed-back Control

Feed-back control is a simple concept that may lead to complex procedures. The idea is to monitor the current output characteristic Y and to make adjustments to the process based on the observed output. By making appropriate adjustments, we compensate for changes in unidentified process inputs, thus reducing the variability in future values of Y . The effect of a simple feed-back control plan is illustrated in Figure 3. Whenever the process output reaches the adjustment limits, the process is re-targeted by making appropriate adjustments. Figure 3 demonstrates the resulting reduction in variability. The effect of feed-back control is determined by the adjustment limits and adjustment procedure.

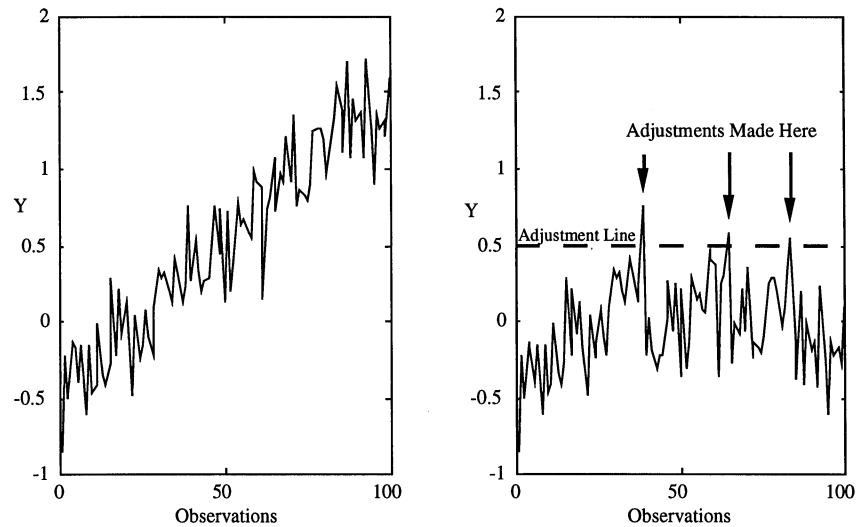

Figure 3: Drift in Process Output Quality

Feed-back control can be successfully applied when three conditions are satisfied. First, the process must be predictable; that is, the past and current output must tell us something about future values. In other words, the process must exhibit structural variation (Joiner, 1994). Examples of structural variation include drift due to tool wear and stratification due to batch to batch variation. Second, there must be a way to re-target the process. Finally, the time to measure the output and adjust the process must be small relative to the rate of change of the process. An existing feed-back control strategy can be altered to reduce variation by addressing one of the three conditions. For example, better knowledge of the nature of the process variation can be used to redesign the adjustment limits.

Feed-back control is used, for example, to reduce variation in the concentration of silicon in molten iron in a foundry. Iron is sampled from the output stream and the concentration of silicon is determined in the sample. Based on the observed concentrations adjustments are made (upstream) to the feed rate of silicon in the melting process. Another common example is the use of setup procedures based on first-off measurements. The major advantage of feed-back control is that it requires little process knowledge. Like final product inspection, it uses measurements on the final product only.

There are a number of drawbacks to feed-back control. A major danger is over adjustment (tampering). If the process is stable, then adjusting on the basis of the output will lead to increased variability. This illustrated in the famous funnel experiment, see Deming, 1986 pp. 327-328. If the pattern of the structural variation is unstable over time, then variation will not be reduced as expected due to inappropriate adjustments. Also, the process measurements and adjustments may be expensive. Finally, due to the feed-back nature of the control, there is an inherent time delay. To identify when an adjustment is required we must first observe some output values that are significantly different from the target value. Thus, feed-back control is always reactive.

There are many ways to monitor the process and decide when to make adjustments. See Tucker, Faltin, and Vander Wiel (1993) for further details. Specific examples include acceptance control charts (Duncan, 1986), Precontrol (Shainin and Shainin, 1989, Juran, 1988). Most feed-back control systems use a function of recent output values, not just the last value, to determine if an adjustment is necessary. If the drift in Y is as regular as shown in Figure 3, we could also base adjustments simply on the time or the number of units processed (or any other cheaply measured variable highly correlated with the output dimension Y).

Reduction of Variation in Process Inputs

As the saying goes “garbage in garbage out.” If there is a large amount of variation in process inputs, then it is difficult to produce consistent output. One improvement approach in this environment is to reduce the variability in one or more inputs. The important input X may be a characteristic of raw materials or component parts, a changing machine setting or any other process input that changes. Reducing variation in inputs corresponds to moving improvement upstream. The problem of reducing variability in X is the analogous to reducing variation in Y . Thus, we have created a recursion in our problem definition, because the input X is the output of some other process. To reduce variability in X we can apply any of the five strategies discussed in this article.

The effect of reducing the variability in an input is illustrated by the variance transmission plots shown in Figure 4. In this example, most of the variation in Y is due to variation in the input

X . As a result, if we reduce the variability in the input X as shown, the variability in the output Y will also be significantly reduced.

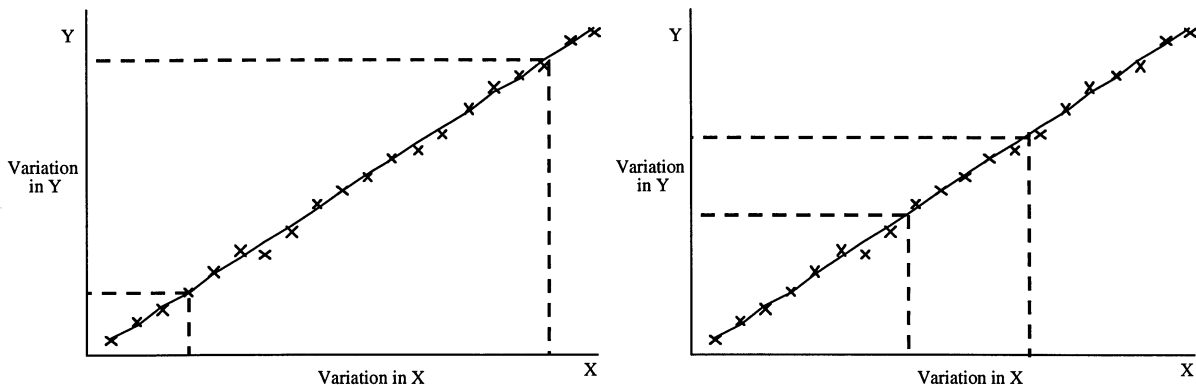

Figure 4: Variance transmission between input X and Output Y

There are three basic conditions necessary for this strategy to work. First, we must be able to identify an input that has a causal influence on the output Y . Thus, a change in X must lead to a change in Y . Second, we must identify an X that is a major source of variation as shown in Figure 4. Third, we must be able to reduce the variation in X .

There are many tools for discovering the identity of such an X . We may use observational studies such as control charts and multi-vari charts or more active approaches such as designed experiments. It is very important that the identified factor X is truly a significant factor influencing the variation in the output.

This approach is proactive. The control of the process is moved upstream which may reduce cost and complexity, and less effort may be needed to monitor the process output Y . An example of this strategy occurred in the machining of the aluminum pistons described above. A variation transmission study identified the piston diameter after an intermediate operation as X , the major source of variation in final piston diameter. The variation of X was reduced by instituting improved operator instructions at the operation and better training of the operators in the use of these instructions.

One difficulty with this strategy is that first we must identify an X , which is both an important contributor to the variation in Y and which is causally related. This may prove arduous

and involves possibly significant study costs. Second, reducing variability in X may be very difficult and/or costly. Third, tightened specifications on X moves the responsibility for control of the process upstream, and possibly outside the influence of local management.

Figure 4 shows a continuously varying input X . However, in many cases X is discrete. For example, X could represent multiple suppliers or multiple machines in parallel processing operations. In this case, reducing variation in X could be accomplished by reducing the number of suppliers or establishing procedures to reduce differences among the suppliers.

Feed-forward Control

Using feed-forward control, we adjust the process in response to measurements made on an input X , anticipating the effect on the output Y . If the measured value of X provides a prediction of the corresponding output Y , feed-forward control can reduce variation in Y by adjusting the process to compensate for different X values. Figure 5 demonstrates the effect of adjusting Y based on knowledge of X and the relationship between X and Y .

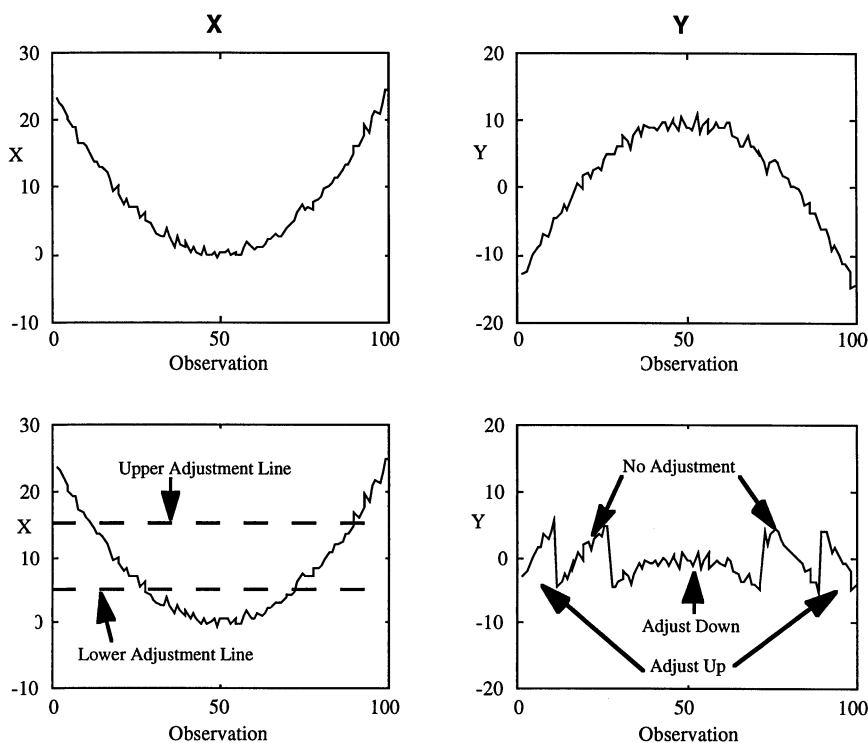

Figure 5: Feed-forward Control

Feed-forward control works under restrictive conditions. First, we must identify an X that is an important source of variation. Second, the relationship between X and Y must be well known and stable over time. Third, we must be able to measure X in a timely way and predict when X will have an effect. Finally, there must be a way to adjust the process to compensate for the changes in X .

Feed-forward control can be very effective if the above conditions are satisfied. A simple example is the use of set-up procedures based on the properties of the raw materials. Another is selective fitting, the technique of sorting and matching component parts to get good assemblies. This procedure has been used to reduce variation in clearance between pistons and cylinder block bore walls by matching piston and bore diameters. Note that this adds additional complexity to the assembly process.

There are substantial costs and risks associated with feed-forward control. Costs arise because we need to determine the relationship between X and Y , measure X , and repeatedly adjust the process when appropriate. As with feed-back control, there is a danger of over adjustment if there is a measurement problem with X or if the relationship between X and Y is not well understood. In addition, repeated process adjustment may be simply impractical or very costly and may introduce other undesired side effects.

Process Desensitization

Desensitization of the process aims to reduce variability by making the process more robust to the variability in process inputs. This is also called parameter design as discussed by Taguchi (1985) and Nair (1992). Desensitizing the process works by identifying and exploiting interactions between important varying inputs X and other normally fixed process parameters. Figure 6 demonstrates how modifying the relationship between Y and X by changing other process parameters results in less variation in Y over the same range of variability in X .

Typically the process settings that yield a more robust process are identified through a designed experiment which uses both X and a set of control factors. The experiment must be designed so that interaction between X and the control factors can be identified.

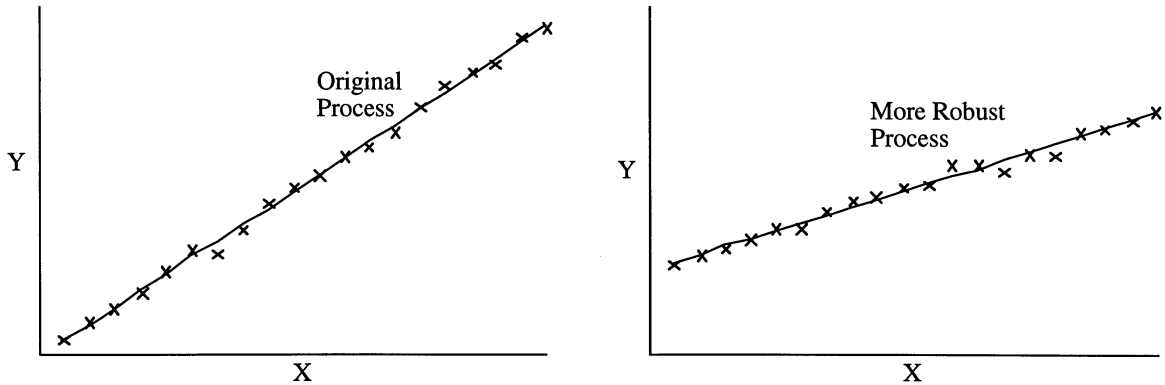

Figure 6: Desensitizing the Process

Process desensitization is a very desirable strategy since once it is complete, no further action is required. Taguchi (1985) cites several examples, including the famous Ina tile case. Another example involved the reduction of variation of sulfur concentration in molten iron where X was the unknown and uncontrollable amount of sulfur in the scrap iron being melted. An experiment identified new settings in the desulfurization process that reduced the within-shift variability in the output molten iron.

It is difficult to predict when desensitizing the process will work. This is one of its great weaknesses. Also, making a process more robust requires a great deal of process knowledge. Determining appropriate settings of the control parameters usually requires expensive designed experiments that may fail to determine settings that lead to improvement. Also, the new process settings may be a more expensive way to run process and require a re-targeting of the process.

In theory, making a process more robust can be accomplished without any knowledge of the factor X , even its identity. Taguchi recommends identifying X (the noise factor) and then conducting an inner-outer array experiment in which X is controlled. An alternative is to define an experimental run as the operation of the process over a period of time sufficiently long to allow the unknown X to vary substantially. Control factors are altered in an organized way for a number of

such runs. The process variability is measured over each run and is then used as the response in the analysis of the experiment. However, without knowing X , we run a significant risk of determining a more robust setting that is only better under the limited operating conditions used in the experiment. It is also more difficult to identify control factors that may be used to reduce the variation when X is not identified.

Examples

In any application, a decision must be made as to which strategy or combination of strategies should be used. To demonstrate the thought process required, we consider two examples. The examples demonstrate that the more you know about the process, the more flexibility there is in choice of strategies. In the first example, all the generic strategies are reasonable. However, the best approach depends on unknown factors, and can not be determined without further study. In the second example, reducing the variation in the inputs was deemed the most cost effective strategy. However, other approaches were potentially feasible.

Example 1: A Multi-batch Process

Suppose we have a process that operates on batches of raw material. A sample of process output is given in Figure 7 where each batch of raw material yields 50 sample points. Clearly, the major shifts in the process correspond to changes in batch of raw material. Given only this information, and the goal of variation reduction what are the possible strategies?

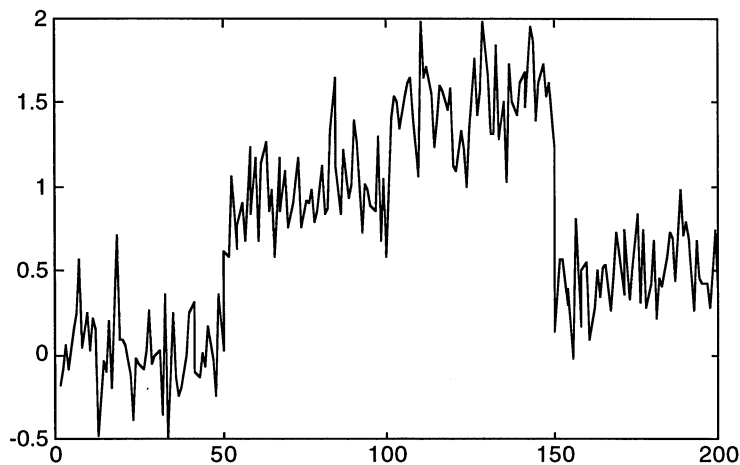

Figure 7: Multi-batch Process Output

If the output is measured on discrete units, then final product inspection coupled with a rework loop will reduce the variability in the output. Because of the large batch to batch variability, lots can be defined based on input batch and sampling inspection can be used to identify discrepant lots. However, in this example, inspection is likely not a good choice because it will provide only minimal improvement unless we are willing to rework many units.

In this example, feed-back control is a good approach. By closely monitor the output Y each time we change batches of raw material, we can estimate the current process mean. Assuming an adjustment mechanism is available, we can then adjust the process to compensate for the batch effect. Feed-back control has the disadvantage that there will be some time after we start a new batch of inputs where we operate the process to determine the magnitude of adjustment required.

Reducing the differences between batches of raw material leads to more consistent batches, thereby creating more consistent output. This is probably the most desirable approach, but will certainly require further study since we do not know what characteristic of the batches is responsible for the variation in Y . That is, we have not identified X .

If we can identify and measure X on each batch, then feed-forward control may be a good choice. If X is a good predictor of Y , and the process target is adjustable, we could compensate

for the batch differences before we use the batch. Note that this avoids the time delay implicit in feed-back control.

Finally, desensitizing the process to variation in batches can also work, but will require an extensive study to determine robust process settings. If we have not identified X , then each run of the experiment will have to include several batches of raw material. The robust settings may not be able to remove the effect of batch difference entirely since, in this example, the differences between batches is large.

Example 2: Crankshaft Machining

Journal diameter is a key product characteristic on machined crankshafts. The machining process is illustrated below in Figure 8. Raw castings are identified by hour, date of casting and mold number. The measurements at the final gauge are monitored informally. If the operator notices a significant number of rejects due to small or large journal diameters, he or she asks for an adjustment in the grinder that produced most of the rejects.

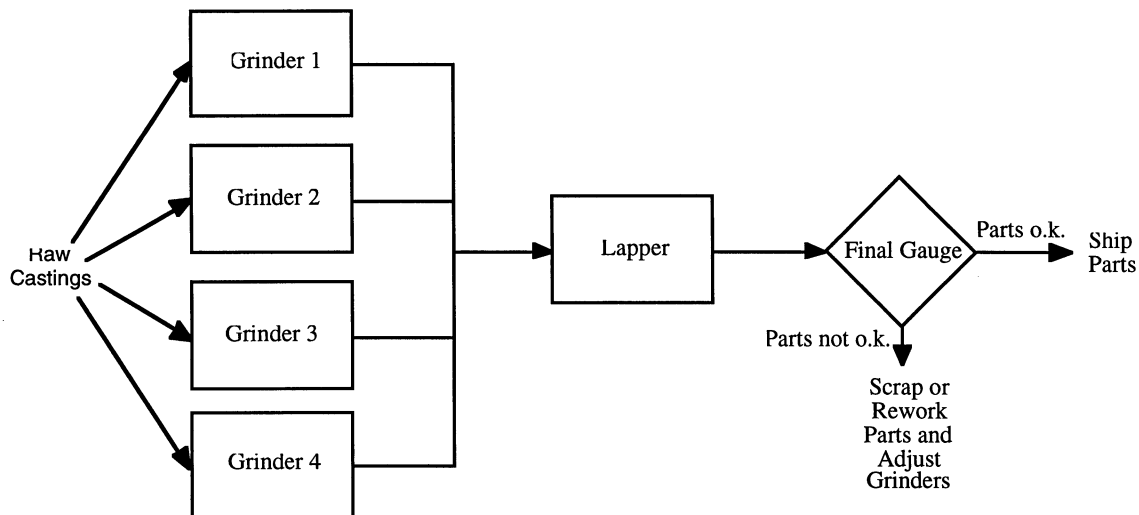

Figure 8: Crankshaft Production Process

The objective is to reduce long term variation in the journal diameters of finished crankshafts. How do we select a strategy?

The first step is to determine current process performance, in terms of stability, structural variation and capability. This requires monitoring process performance at the final stage. Without this knowledge, it is difficult to assess which, if any strategy, is likely to be effective.

The simplest approach is to tighten the inspection limits. The consequence is an increase in scrap and rework and lost capacity, which in this case is considered too expensive. A second possibility is to consider improving the current feed-back control. This involves defining a standardized procedure that all operators will follow that makes better use of the final inspection data. Since changing people's behavior is difficult, and because there is a large number of in-process crankshafts between the grinders and the final gauge, consideration of this choice is postponed. The next step is to identify X, an important source of variability in the journal diameters. A modified multi-vari study (Juran, 1988) was carried out that considered the lapper, the grinders and lot of castings as major potential sources of variability. This study was inexpensive because it involved measuring and recording journal diameters on a purposely selected sample of crankshafts before lapping and at final inspection. The results show large grinder to grinder differences in average diameter before lapping which was transmitted to the final diameter. As a result, the grinders were identified as the major source of variation.

The remaining three strategies can now be considered. The first possibility is to change the control plan on the grinders so that each is targeted to the same value (reduce input variation). The second possibility is to change the transfer process between the grinders and the lappers so that the lapper works on a batch of crankshafts from a single grinder. Then feed-forward control is possible because the lapper can be set to remove more material from batches with larger average incoming diameters. Note that the major purpose of the lapper is to improve surface finish so that this would be a change in function. Another possibility considered was the use of a "smart" lapper that would measure the incoming journal size and change the lapping time accordingly. These feed-forward schemes were both rejected due to high cost. The strategy to desensitize the process due to the variation in after-grind diameter was briefly considered and rejected because there were no control factors in the lapping operation that could be feasibly used.

The elimination process left grinder control as the only feasible strategy. This required a further investigation of the current control plan for the grinder operation. A better feed-back control system using the diameter after grinding was then implemented.

Summary and Conclusions

This article compares and contrasts five variation reduction techniques. We believe these five techniques either singly or in combination encompass all possible reduction methods. The goal of the article is to describe and explain the various methods and to aid the practitioner in making a judicious choice of technique. Figure 9 provides a tree diagram showing the major divisions leading to an appropriate choice. X refers to a significant input and Y refers to the critical output dimension. The process knowledge requirement and potential risks of the different variation reduction methods have been summarized in Table 1.

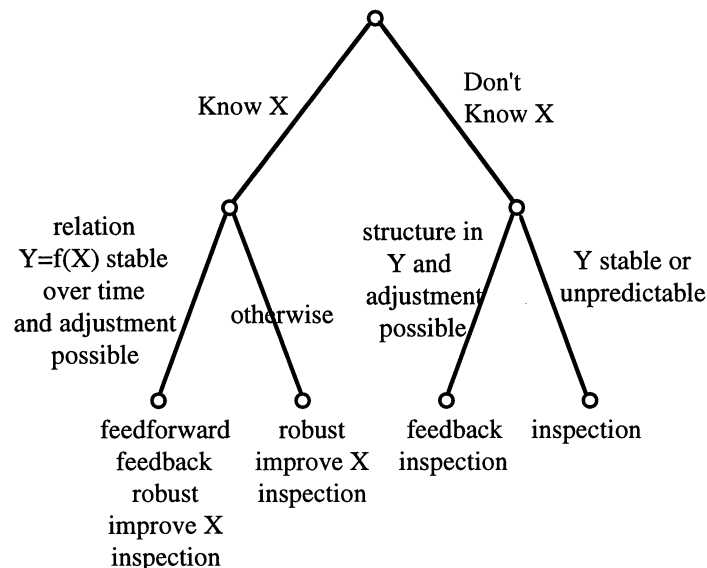

Figure 9: Decision Tree to Determine Appropriate Variance Reduction Strategy

Reduction of variation requires either a change in the process or a change in the control of a process. Adopting final product inspection, feed-back control, reduction of variation in inputs, or feed-forward control leads to a change in the process control plan. Process desensitization, on the

other hand, leads to a change in the process, and does not necessarily effect the control plan. However with a more robust process, it is possible that the control plan rules could be relaxed.

References

- Advanced Product Quality Planning and Control Plan: Reference Manual*, (1994), Automotive Industry Action Group.
- Deming, W. E. (1982), "Out of the Crisis," MIT Center for Advanced Engineering Study.
- Duncan, A.J. (1986), *Quality Control and Industrial Statistics* (5th ed.), Homewood, IL: Richard D. Irwin.
- Joiner B.L. (1994), "Fourth Generation Management: The New Business Consciousness," McGraw-Hill, New York.
- Juran, J.M. (1988), "Quality Control Handbook, 4th edition, McGraw-Hill, New York.
- Nair, V.N. (1992), "Taguchi's Parameter Design - A Panel Discussion," editor, *Technometrics*, Vol. 34, 127-162.
- Shainin D., Shainin, P. (1989), "Pre-Control versus \bar{X} and R charting: continuous or immediate quality improvement?," *Quality Engineering*, Vol. 1, 419-429.
- Taguchi, G., Wu, Y. (1985), Introduction to Off-line Quality Control, Central Japan Quality Control Association.
- Taguchi, G. (1986), Introduction to Quality Engineering, UNIPUB/Kraus International Publications, White Plains, NY.
- Tucker, W.T., Faltin, F.W., Vander Wiel, S.A. (1993), "Algorithm Statistical Process Control: An Elaboration," *Technometrics*, Vol. 35, 363-375.



Strategies for Variability Reduction

R. Jock MacKay and Stefan Steiner
University of Waterloo

I.I.Q.P. Research Report
RR-95-11
October 1995

THE INSTITUTE FOR
IMPROVEMENT IN QUALITY
AND PRODUCTIVITY

University of Waterloo
Waterloo, Ontario, Canada
N2L 3G1
(519) 888-4593

Strategies for Variability Reduction

R. Jock MacKay and Stefan H. Steiner
Department of Statistics and Actuarial Sciences
Institute for Improvement in Quality and Productivity
University of Waterloo
Waterloo, Ontario
Canada N2L 3G1

Abstract

An important goal of quality improvement in manufacturing is the reduction of variability in characteristics of process output. Producing more consistent output improves product performance and may reduce manufacturing costs. This article discusses and contrasts five generic variation reduction techniques that encompass all current methods. The five approaches are: final product inspection, feed-back control, reduction of variation in process inputs, feed-forward control, and process desensitization. Each technique has distinct advantages and disadvantages and is only applicable in certain circumstances. The article discusses the various techniques and provides practitioners guidance in choosing the most appropriate approach. Two examples that illustrate the thought process necessary to choose appropriately are given.

Introduction

An important goal of quality improvement in manufacturing is the reduction of variability in characteristics of process output. Producing more consistent output improves product performance and may reduce manufacturing costs.

The problem can be simply demonstrated. Suppose a process produces output with an important quality characteristic Y . See Figure 1. The current process performance, measured over a long enough period to be stable, is shown by the histogram. The goal is to reduce variability in Y while targeting the process at or near the nominal value. In this article, we focus on variation reduction, and implicitly assume either that any reduction obtained does not move the process mean significantly away from its target or that we can re-target the process mean without effecting the process variability. In this way, reducing the variability in Y will improve the process capability.

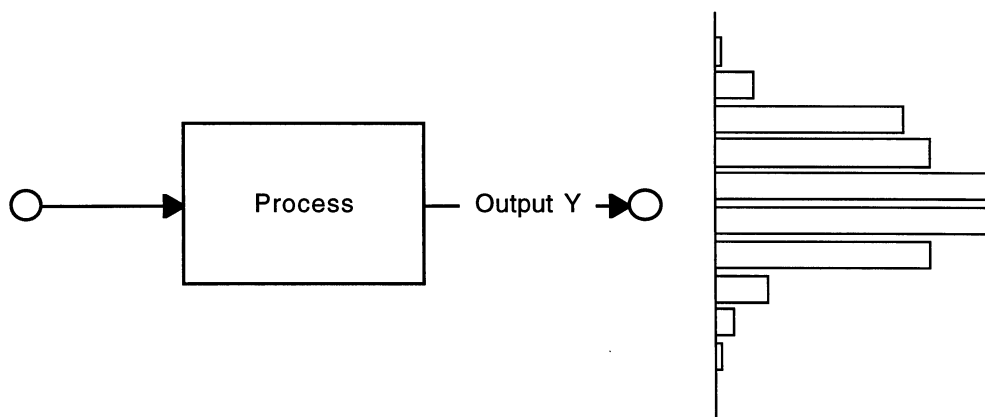

Figure 1: Process Diagram

Reduction in variation can be accomplished in a number of ways. In our experience, all approaches can be classified into one of five generic strategies:

1. final product inspection;
2. feed-back control;
3. reduction of variation in process inputs;
4. feed-forward control;

5. process desensitization.

All five strategies are currently used in industry. Every process is managed using one, or more usually, a combination of strategies 1 to 4, whereas strategy 5 is solely an improvement technique. Reducing the variation inherent in an existing process requires the modification of a current strategy or the adoption of a new one. No reduction in variation can be achieved without changing either the process or how it is managed. Process monitoring (e.g. control charts) on either outputs or inputs may lead to understanding of how the process operates but will not, by itself, result in variation reduction.

This corresponds to the idea of a living control plan as discussed in the AIAG reference manual, *Advanced Product Quality Planning and Control Plan*. This manual is referenced in the automotive industry quality standard, QS-9000. A control plan specifies the mechanisms through which the quality of a product will be monitored, controlled, and verified. A living control plan is constantly modified and improved as more information on the process becomes available.

The goal of this article is to contrast and compare each of the variation reduction strategies, highlighting the required process knowledge, potential costs and benefits of each method. Each strategy has potential advantages and drawbacks and is applicable only in certain circumstances. The choice of an effective strategy depends critically on knowledge of the existing process. Key issues include stability, predictability, ability to adjust, and identification of the causes of the variation. The availability and cost of attaining this knowledge provides a key input to a decision on which process variation reduction strategy is most applicable. We hope that this discussion will provide guidance to quality practitioners faced with a variation reduction problem.

Final Product Inspection

Final product inspection is the simplest variation reduction strategy and is virtually always applicable. Variability is reduced by identifying and then scrapping or reworking all items that have values of Y beyond selected inspection limits. The more the limits are tightened, the greater is the reduction in variation. The effect of tightened inspection is illustrated in Figure 2. Imagine

inspecting and sorting units based on whether they fall between the dashed lines shown, where any units falling outside the limits are either scrapped or reworked (and then re-inspected). Clearly, this selection of units reduces the overall variability in the process output that is subsequently shipped.

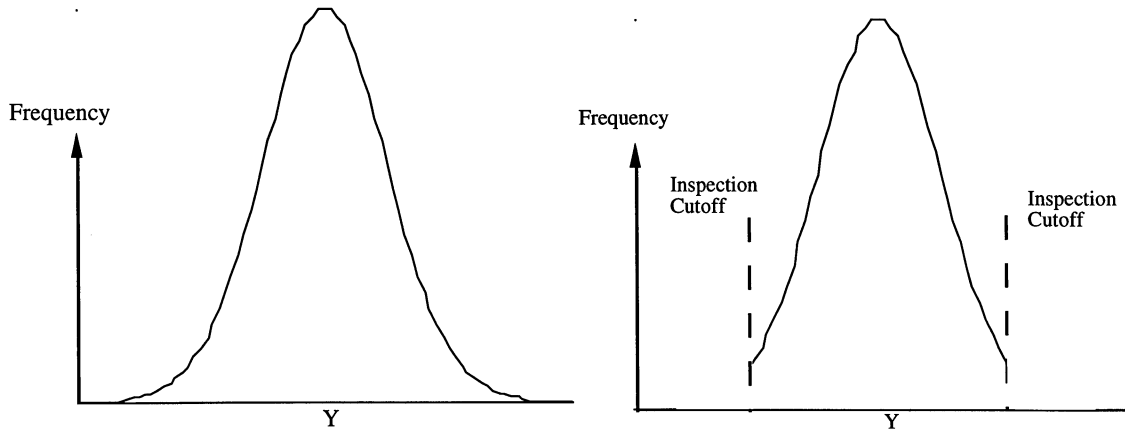

Figure 2: Final Product Inspection Strategy

Final product inspection is very versatile. It can be successfully used in any situation where the output characteristic Y can be determined in advance of shipping the product to a customer. Final product inspection is especially appropriate when the quality dimension is critical and the process produces only the occasional outlier or flier while all other units exhibit very little variation. For example, in the production of aluminum pistons, the diameter of each finished piston (as well as a number of other key characteristics) is measured by an automated gauge after the piston temperature is controlled. Pistons with large or small diameters are scrapped. In such a situation, the costs associated with 100% inspection, including installation and operation of the automated gauge, are warranted due to the high production volume and the critical nature of the product characteristic. Assuming no inspection error, the 100% inspection strategy has the advantage of being able to guarantee that no units with quality characteristic outside the inspection limits will be shipped to a customer.

Final product inspection has a number of significant negative features. The cost of reducing variability by tightening the inspection limits may be very high due to increased rework and scrap costs and lost capacity. Also, the cost of inspection itself may be large if new gauging or

additional labour is required. Measurement or inspection errors will result in increased variability. As a result, given the propensity of people to make inspection errors, most successful applications use automated inspection. As shown in Figure 1, the resultant quality of many of the units passed through our inspection procedure may be just barely inside the cutoff values. As a result, from a loss function perspective (Taguchi, 1986), inspection may be a poor approach since the output may be only marginally better after the inspection procedure. Finally, inspection is applicable to processes with continuous flows only if the production is divided into batches.

One common modification of this strategy is inspection sampling where not every unit is measured. This requires the definition of a lot. Lots are accepted or rejected based on the quality of a sample taken from the lot. Accepted lots are shipped and rejected lots are 100% inspected or otherwise disposed. If we know that lot to lot variation is large and within lot variation is small, then inspection sampling is effective. Thus, using inspection sampling, variation may be reduced by redefining a lot, changing the acceptance criteria, or changing the inspection limits. Compared to 100% inspection, inspection costs are reduced. However, overall variability will not be reduced to the same degree. Note that if the process is stable, then partial inspection is a poor strategy. Deming (Chapter 15, 1986) showed that in this case either no or complete 100% inspection is optimal.

Feed-back Control

Feed-back control is a simple concept that may lead to complex procedures. The idea is to monitor the current output characteristic Y and to make adjustments to the process based on the observed output. By making appropriate adjustments, we compensate for changes in unidentified process inputs, thus reducing the variability in future values of Y . The effect of a simple feed-back control plan is illustrated in Figure 3. Whenever the process output reaches the adjustment limits, the process is re-targeted by making appropriate adjustments. Figure 3 demonstrates the resulting reduction in variability. The effect of feed-back control is determined by the adjustment limits and adjustment procedure.

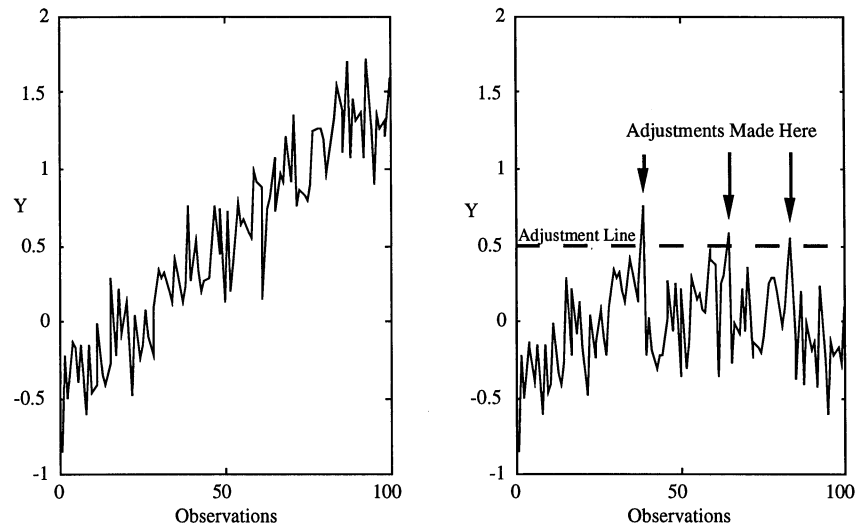

Figure 3: Drift in Process Output Quality

Feed-back control can be successfully applied when three conditions are satisfied. First, the process must be predictable; that is, the past and current output must tell us something about future values. In other words, the process must exhibit structural variation (Joiner, 1994). Examples of structural variation include drift due to tool wear and stratification due to batch to batch variation. Second, there must be a way to re-target the process. Finally, the time to measure the output and adjust the process must be small relative to the rate of change of the process. An existing feed-back control strategy can be altered to reduce variation by addressing one of the three conditions. For example, better knowledge of the nature of the process variation can be used to redesign the adjustment limits.

Feed-back control is used, for example, to reduce variation in the concentration of silicon in molten iron in a foundry. Iron is sampled from the output stream and the concentration of silicon is determined in the sample. Based on the observed concentrations adjustments are made (upstream) to the feed rate of silicon in the melting process. Another common example is the use of setup procedures based on first-off measurements. The major advantage of feed-back control is that it requires little process knowledge. Like final product inspection, it uses measurements on the final product only.

There are a number of drawbacks to feed-back control. A major danger is over adjustment (tampering). If the process is stable, then adjusting on the basis of the output will lead to increased variability. This illustrated in the famous funnel experiment, see Deming, 1986 pp. 327-328. If the pattern of the structural variation is unstable over time, then variation will not be reduced as expected due to inappropriate adjustments. Also, the process measurements and adjustments may be expensive. Finally, due to the feed-back nature of the control, there is an inherent time delay. To identify when an adjustment is required we must first observe some output values that are significantly different from the target value. Thus, feed-back control is always reactive.

There are many ways to monitor the process and decide when to make adjustments. See Tucker, Faltin, and Vander Wiel (1993) for further details. Specific examples include acceptance control charts (Duncan, 1986), Precontrol (Shainin and Shainin, 1989, Juran, 1988). Most feed-back control systems use a function of recent output values, not just the last value, to determine if an adjustment is necessary. If the drift in Y is as regular as shown in Figure 3, we could also base adjustments simply on the time or the number of units processed (or any other cheaply measured variable highly correlated with the output dimension Y).

Reduction of Variation in Process Inputs

As the saying goes “garbage in garbage out.” If there is a large amount of variation in process inputs, then it is difficult to produce consistent output. One improvement approach in this environment is to reduce the variability in one or more inputs. The important input X may be a characteristic of raw materials or component parts, a changing machine setting or any other process input that changes. Reducing variation in inputs corresponds to moving improvement upstream. The problem of reducing variability in X is the analogous to reducing variation in Y . Thus, we have created a recursion in our problem definition, because the input X is the output of some other process. To reduce variability in X we can apply any of the five strategies discussed in this article.

The effect of reducing the variability in an input is illustrated by the variance transmission plots shown in Figure 4. In this example, most of the variation in Y is due to variation in the input

X . As a result, if we reduce the variability in the input X as shown, the variability in the output Y will also be significantly reduced.

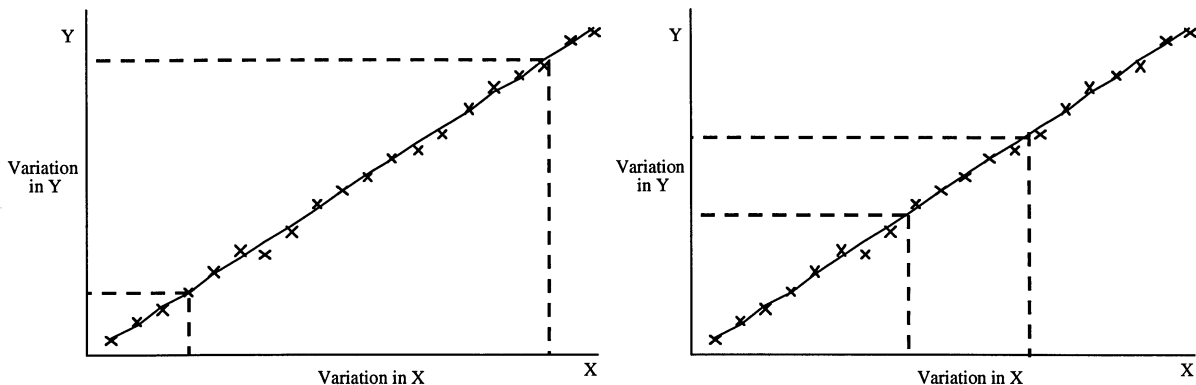

Figure 4: Variance transmission between input X and Output Y

There are three basic conditions necessary for this strategy to work. First, we must be able to identify an input that has a causal influence on the output Y . Thus, a change in X must lead to a change in Y . Second, we must identify an X that is a major source of variation as shown in Figure 4. Third, we must be able to reduce the variation in X .

There are many tools for discovering the identity of such an X . We may use observational studies such as control charts and multi-vari charts or more active approaches such as designed experiments. It is very important that the identified factor X is truly a significant factor influencing the variation in the output.

This approach is proactive. The control of the process is moved upstream which may reduce cost and complexity, and less effort may be needed to monitor the process output Y . An example of this strategy occurred in the machining of the aluminum pistons described above. A variation transmission study identified the piston diameter after an intermediate operation as X , the major source of variation in final piston diameter. The variation of X was reduced by instituting improved operator instructions at the operation and better training of the operators in the use of these instructions.

One difficulty with this strategy is that first we must identify an X , which is both an important contributor to the variation in Y and which is causally related. This may prove arduous

and involves possibly significant study costs. Second, reducing variability in X may be very difficult and/or costly. Third, tightened specifications on X moves the responsibility for control of the process upstream, and possibly outside the influence of local management.

Figure 4 shows a continuously varying input X . However, in many cases X is discrete. For example, X could represent multiple suppliers or multiple machines in parallel processing operations. In this case, reducing variation in X could be accomplished by reducing the number of suppliers or establishing procedures to reduce differences among the suppliers.

Feed-forward Control

Using feed-forward control, we adjust the process in response to measurements made on an input X , anticipating the effect on the output Y . If the measured value of X provides a prediction of the corresponding output Y , feed-forward control can reduce variation in Y by adjusting the process to compensate for different X values. Figure 5 demonstrates the effect of adjusting Y based on knowledge of X and the relationship between X and Y .

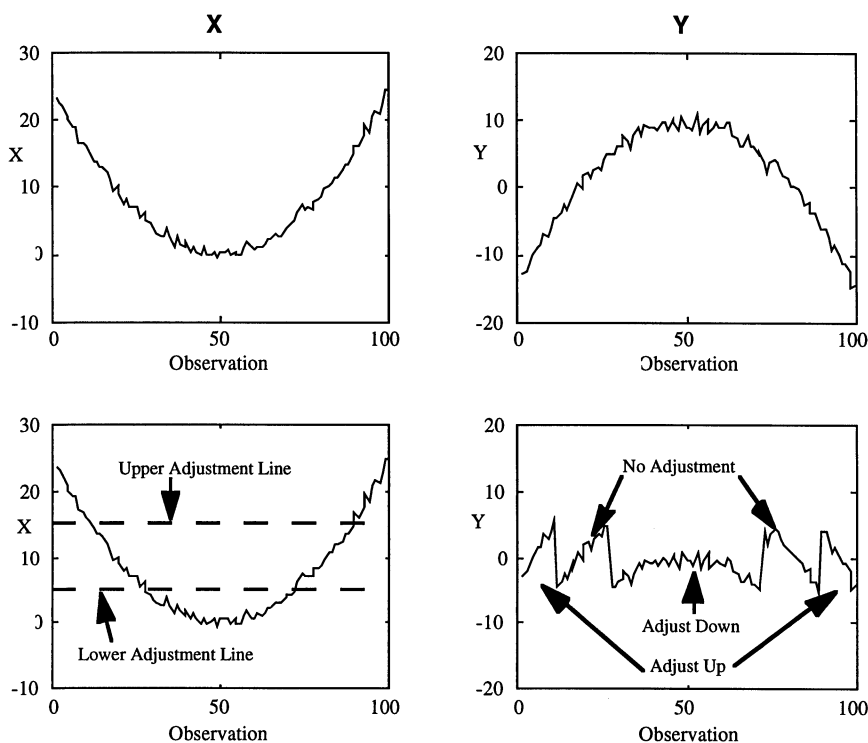

Figure 5: Feed-forward Control

Feed-forward control works under restrictive conditions. First, we must identify an X that is an important source of variation. Second, the relationship between X and Y must be well known and stable over time. Third, we must be able to measure X in a timely way and predict when X will have an effect. Finally, there must be a way to adjust the process to compensate for the changes in X .

Feed-forward control can be very effective if the above conditions are satisfied. A simple example is the use of set-up procedures based on the properties of the raw materials. Another is selective fitting, the technique of sorting and matching component parts to get good assemblies. This procedure has been used to reduce variation in clearance between pistons and cylinder block bore walls by matching piston and bore diameters. Note that this adds additional complexity to the assembly process.

There are substantial costs and risks associated with feed-forward control. Costs arise because we need to determine the relationship between X and Y , measure X , and repeatedly adjust the process when appropriate. As with feed-back control, there is a danger of over adjustment if there is a measurement problem with X or if the relationship between X and Y is not well understood. In addition, repeated process adjustment may be simply impractical or very costly and may introduce other undesired side effects.

Process Desensitization

Desensitization of the process aims to reduce variability by making the process more robust to the variability in process inputs. This is also called parameter design as discussed by Taguchi (1985) and Nair (1992). Desensitizing the process works by identifying and exploiting interactions between important varying inputs X and other normally fixed process parameters. Figure 6 demonstrates how modifying the relationship between Y and X by changing other process parameters results in less variation in Y over the same range of variability in X .

Typically the process settings that yield a more robust process are identified through a designed experiment which uses both X and a set of control factors. The experiment must be designed so that interaction between X and the control factors can be identified.

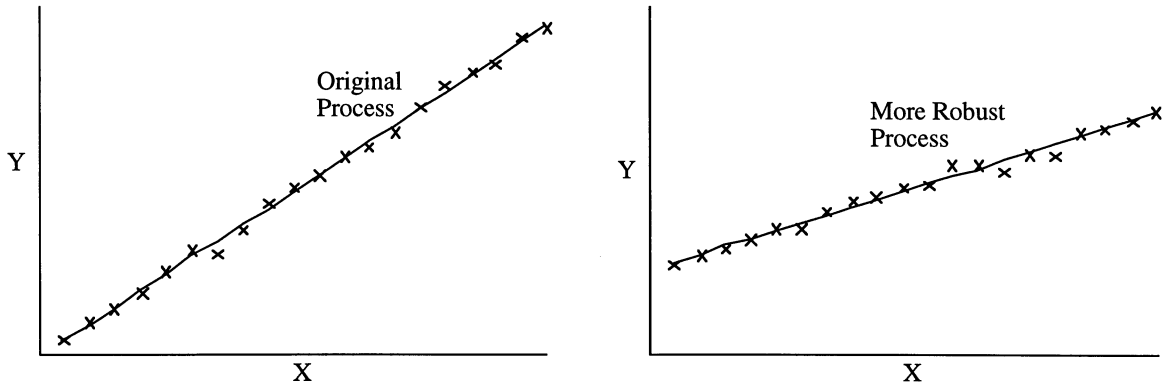

Figure 6: Desensitizing the Process

Process desensitization is a very desirable strategy since once it is complete, no further action is required. Taguchi (1985) cites several examples, including the famous Ina tile case. Another example involved the reduction of variation of sulfur concentration in molten iron where X was the unknown and uncontrollable amount of sulfur in the scrap iron being melted. An experiment identified new settings in the desulfurization process that reduced the within-shift variability in the output molten iron.

It is difficult to predict when desensitizing the process will work. This is one of its great weaknesses. Also, making a process more robust requires a great deal of process knowledge. Determining appropriate settings of the control parameters usually requires expensive designed experiments that may fail to determine settings that lead to improvement. Also, the new process settings may be a more expensive way to run process and require a re-targeting of the process.

In theory, making a process more robust can be accomplished without any knowledge of the factor X , even its identity. Taguchi recommends identifying X (the noise factor) and then conducting an inner-outer array experiment in which X is controlled. An alternative is to define an experimental run as the operation of the process over a period of time sufficiently long to allow the unknown X to vary substantially. Control factors are altered in an organized way for a number of

such runs. The process variability is measured over each run and is then used as the response in the analysis of the experiment. However, without knowing X , we run a significant risk of determining a more robust setting that is only better under the limited operating conditions used in the experiment. It is also more difficult to identify control factors that may be used to reduce the variation when X is not identified.

Examples

In any application, a decision must be made as to which strategy or combination of strategies should be used. To demonstrate the thought process required, we consider two examples. The examples demonstrate that the more you know about the process, the more flexibility there is in choice of strategies. In the first example, all the generic strategies are reasonable. However, the best approach depends on unknown factors, and can not be determined without further study. In the second example, reducing the variation in the inputs was deemed the most cost effective strategy. However, other approaches were potentially feasible.

Example 1: A Multi-batch Process

Suppose we have a process that operates on batches of raw material. A sample of process output is given in Figure 7 where each batch of raw material yields 50 sample points. Clearly, the major shifts in the process correspond to changes in batch of raw material. Given only this information, and the goal of variation reduction what are the possible strategies?

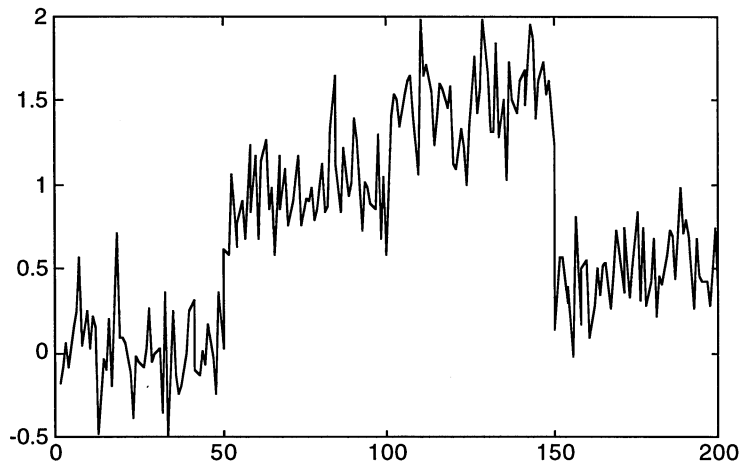

Figure 7: Multi-batch Process Output

If the output is measured on discrete units, then final product inspection coupled with a rework loop will reduce the variability in the output. Because of the large batch to batch variability, lots can be defined based on input batch and sampling inspection can be used to identify discrepant lots. However, in this example, inspection is likely not a good choice because it will provide only minimal improvement unless we are willing to rework many units.

In this example, feed-back control is a good approach. By closely monitor the output Y each time we change batches of raw material, we can estimate the current process mean. Assuming an adjustment mechanism is available, we can then adjust the process to compensate for the batch effect. Feed-back control has the disadvantage that there will be some time after we start a new batch of inputs where we operate the process to determine the magnitude of adjustment required.

Reducing the differences between batches of raw material leads to more consistent batches, thereby creating more consistent output. This is probably the most desirable approach, but will certainly require further study since we do not know what characteristic of the batches is responsible for the variation in Y . That is, we have not identified X .

If we can identify and measure X on each batch, then feed-forward control may be a good choice. If X is a good predictor of Y , and the process target is adjustable, we could compensate

for the batch differences before we use the batch. Note that this avoids the time delay implicit in feed-back control.

Finally, desensitizing the process to variation in batches can also work, but will require an extensive study to determine robust process settings. If we have not identified X , then each run of the experiment will have to include several batches of raw material. The robust settings may not be able to remove the effect of batch difference entirely since, in this example, the differences between batches is large.

Example 2: Crankshaft Machining

Journal diameter is a key product characteristic on machined crankshafts. The machining process is illustrated below in Figure 8. Raw castings are identified by hour, date of casting and mold number. The measurements at the final gauge are monitored informally. If the operator notices a significant number of rejects due to small or large journal diameters, he or she asks for an adjustment in the grinder that produced most of the rejects.

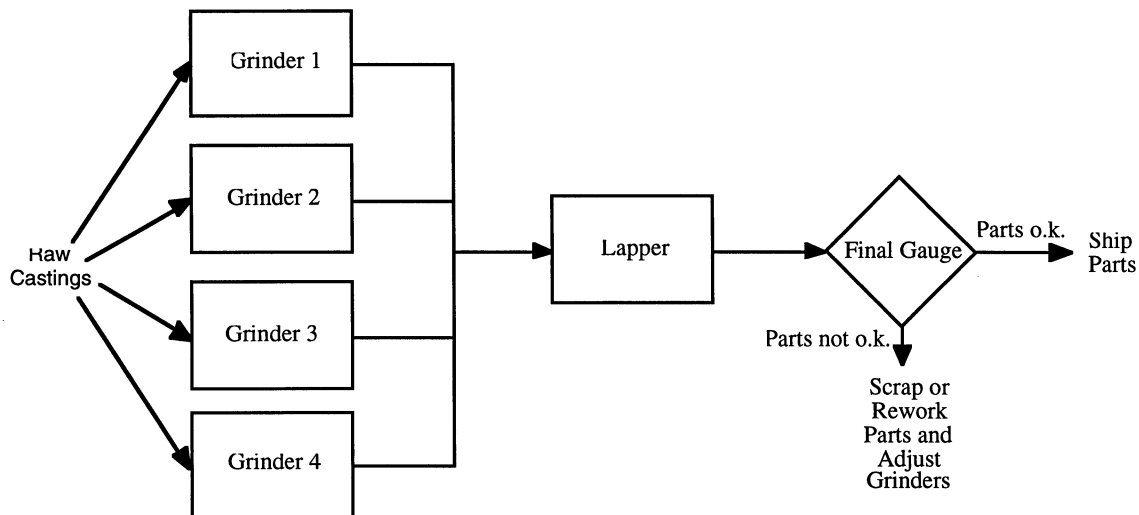

Figure 8: Crankshaft Production Process

The objective is to reduce long term variation in the journal diameters of finished crankshafts. How do we select a strategy?

The first step is to determine current process performance, in terms of stability, structural variation and capability. This requires monitoring process performance at the final stage. Without this knowledge, it is difficult to assess which, if any strategy, is likely to be effective.

The simplest approach is to tighten the inspection limits. The consequence is an increase in scrap and rework and lost capacity, which in the this case is considered too expensive. A second possibility is to consider improving the current feed-back control. This involves defining a standardized procedure that all operators will follow that makes better use of the final inspection data. Since changing people's behavior is difficult, and because there is a large number of in-process crankshafts between the grinders and the final gauge, consideration of this choice is postponed. The next step is to identify X, an important source of variability in the journal diameters. A modified multi-vari study (Juran, 1988) was carried out that considered the lapper, the grinders and lot of castings as major potential sources of variability. This study was inexpensive because it involved measuring and recording journal diameters on a purposely selected sample of crankshafts before lapping and at final inspection. The results show large grinder to grinder differences in average diameter before lapping which was transmitted to the final diameter. As a result, the grinders were identified as the major source of variation.

The remaining three strategies can now be considered. The first possibility is to change the control plan on the grinders so that each is targeted to the same value (reduce input variation). The second possibility is to change the transfer process between the grinders and the lappers so that the lapper works on a batch of crankshafts from a single grinder. Then feed-forward control is possible because the lapper can be set to remove more material from batches with larger average incoming diameters. Note that the major purpose of the lapper is to improve surface finish so that this would be a change in function. Another possibility considered was the use of a "smart" lapper that would measure the incoming journal size and change the lapping time accordingly. These feed-forward schemes were both rejected due to high cost. The strategy to desensitize the process due to the variation in after-grind diameter was briefly considered and rejected because there were no control factors in the lapping operation that could be feasibly used.

The elimination process left grinder control as the only feasible strategy. This required a further investigation of the current control plan for the grinder operation. A better feed-back control system using the diameter after grinding was then implemented.

Summary and Conclusions

This article compares and contrasts five variation reduction techniques. We believe these five techniques either singly or in combination encompass all possible reduction methods. The goal of the article is to describe and explain the various methods and to aid the practitioner in making a judicious choice of technique. Figure 9 provides a tree diagram showing the major divisions leading to an appropriate choice. X refers to a significant input and Y refers to the critical output dimension. The process knowledge requirement and potential risks of the different variation reduction methods have been summarized in Table 1.

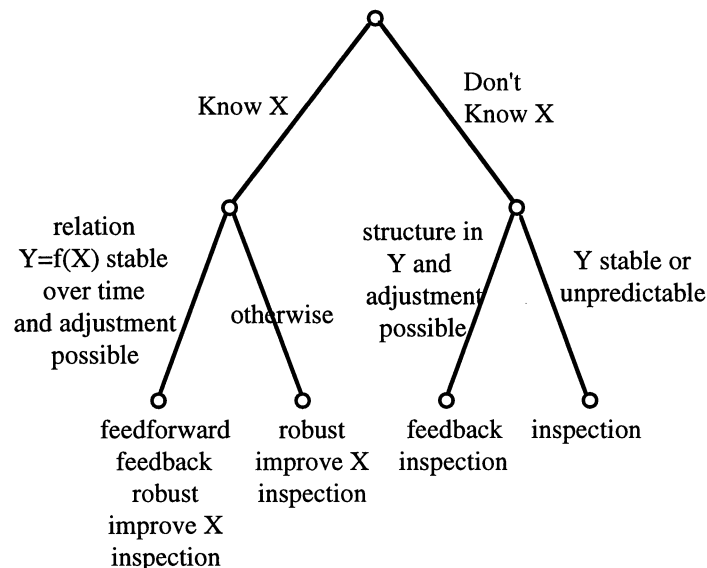

Figure 9: Decision Tree to Determine Appropriate Variance Reduction Strategy

Reduction of variation requires either a change in the process or a change in the control of a process. Adopting final product inspection, feed-back control, reduction of variation in inputs, or feed-forward control leads to a change in the process control plan. Process desensitization, on the

other hand, leads to a change in the process, and does not necessarily effect the control plan. However with a more robust process, it is possible that the control plan rules could be relaxed.

References

- Advanced Product Quality Planning and Control Plan: Reference Manual*, (1994), Automotive Industry Action Group.
- Deming, W. E. (1982), "Out of the Crisis," MIT Center for Advanced Engineering Study.
- Duncan, A.J. (1986), *Quality Control and Industrial Statistics* (5th ed.), Homewood, IL: Richard D. Irwin.
- Joiner B.L. (1994), "Fourth Generation Management: The New Business Consciousness," McGraw-Hill, New York.
- Juran, J.M. (1988), "Quality Control Handbook, 4th edition, McGraw-Hill, New York.
- Nair, V.N. (1992), "Taguchi's Parameter Design - A Panel Discussion," editor, *Technometrics*, Vol. 34, 127-162.
- Shainin D., Shainin, P. (1989), "Pre-Control versus \bar{X} and R charting: continuous or immediate quality improvement?," *Quality Engineering*, Vol. 1, 419-429.
- Taguchi, G., Wu, Y. (1985), Introduction to Off-line Quality Control, Central Japan Quality Control Association.
- Taguchi, G. (1986), Introduction to Quality Engineering, UNIPUB/Kraus International Publications, White Plains, NY.
- Tucker, W.T., Faltin, F.W., Vander Wiel, S.A. (1993), "Algorithm Statistical Process Control: An Elaboration," *Technometrics*, Vol. 35, 363-375.



Strategies for Variability Reduction

R. Jock MacKay and Stefan Steiner
University of Waterloo

I.I.Q.P. Research Report
RR-95-11
October 1995

THE INSTITUTE FOR
IMPROVEMENT IN QUALITY
AND PRODUCTIVITY

University of Waterloo
Waterloo, Ontario, Canada
N2L 3G1
(519) 888-4593

Strategies for Variability Reduction

R. Jock MacKay and Stefan H. Steiner
Department of Statistics and Actuarial Sciences
Institute for Improvement in Quality and Productivity
University of Waterloo
Waterloo, Ontario
Canada N2L 3G1

Abstract

An important goal of quality improvement in manufacturing is the reduction of variability in characteristics of process output. Producing more consistent output improves product performance and may reduce manufacturing costs. This article discusses and contrasts five generic variation reduction techniques that encompass all current methods. The five approaches are: final product inspection, feed-back control, reduction of variation in process inputs, feed-forward control, and process desensitization. Each technique has distinct advantages and disadvantages and is only applicable in certain circumstances. The article discusses the various techniques and provides practitioners guidance in choosing the most appropriate approach. Two examples that illustrate the thought process necessary to choose appropriately are given.

Introduction

An important goal of quality improvement in manufacturing is the reduction of variability in characteristics of process output. Producing more consistent output improves product performance and may reduce manufacturing costs.

The problem can be simply demonstrated. Suppose a process produces output with an important quality characteristic Y . See Figure 1. The current process performance, measured over a long enough period to be stable, is shown by the histogram. The goal is to reduce variability in Y while targeting the process at or near the nominal value. In this article, we focus on variation reduction, and implicitly assume either that any reduction obtained does not move the process mean significantly away from its target or that we can re-target the process mean without effecting the process variability. In this way, reducing the variability in Y will improve the process capability.

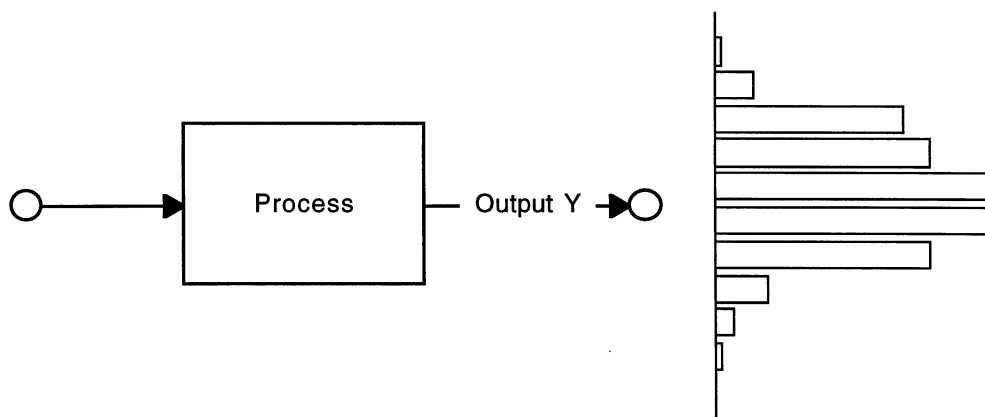

Figure 1: Process Diagram

Reduction in variation can be accomplished in a number of ways. In our experience, all approaches can be classified into one of five generic strategies:

1. final product inspection;
2. feed-back control;
3. reduction of variation in process inputs;
4. feed-forward control;

5. process desensitization.

All five strategies are currently used in industry. Every process is managed using one, or more usually, a combination of strategies 1 to 4, whereas strategy 5 is solely an improvement technique. Reducing the variation inherent in an existing process requires the modification of a current strategy or the adoption of a new one. No reduction in variation can be achieved without changing either the process or how it is managed. Process monitoring (e.g. control charts) on either outputs or inputs may lead to understanding of how the process operates but will not, by itself, result in variation reduction.

This corresponds to the idea of a living control plan as discussed in the AIAG reference manual, *Advanced Product Quality Planning and Control Plan*. This manual is referenced in the automotive industry quality standard, QS-9000. A control plan specifies the mechanisms through which the quality of a product will be monitored, controlled, and verified. A living control plan is constantly modified and improved as more information on the process becomes available.

The goal of this article is to contrast and compare each of the variation reduction strategies, highlighting the required process knowledge, potential costs and benefits of each method. Each strategy has potential advantages and drawbacks and is applicable only in certain circumstances. The choice of an effective strategy depends critically on knowledge of the existing process. Key issues include stability, predictability, ability to adjust, and identification of the causes of the variation. The availability and cost of attaining this knowledge provides a key input to a decision on which process variation reduction strategy is most applicable. We hope that this discussion will provide guidance to quality practitioners faced with a variation reduction problem.

Final Product Inspection

Final product inspection is the simplest variation reduction strategy and is virtually always applicable. Variability is reduced by identifying and then scrapping or reworking all items that have values of Y beyond selected inspection limits. The more the limits are tightened, the greater is the reduction in variation. The effect of tightened inspection is illustrated in Figure 2. Imagine

inspecting and sorting units based on whether they fall between the dashed lines shown, where any units falling outside the limits are either scrapped or reworked (and then re-inspected). Clearly, this selection of units reduces the overall variability in the process output that is subsequently shipped.

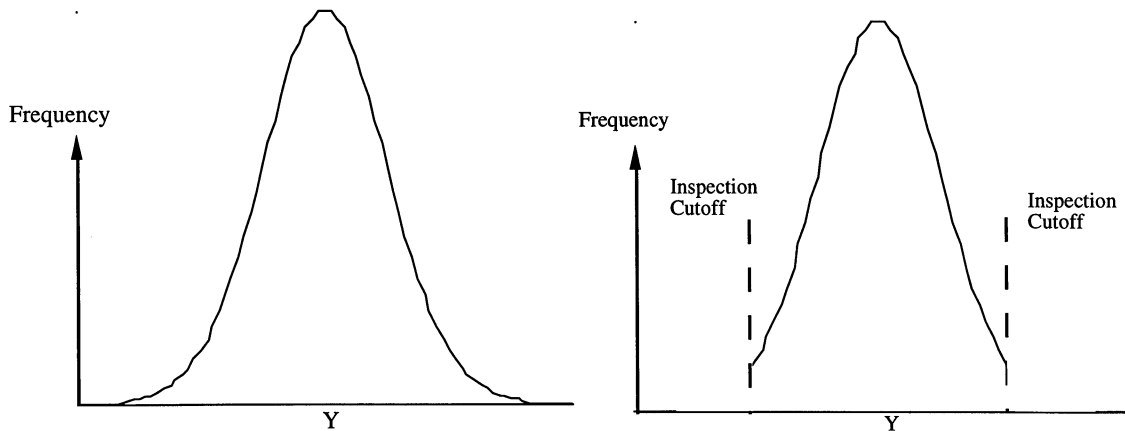

Figure 2: Final Product Inspection Strategy

Final product inspection is very versatile. It can be successfully used in any situation where the output characteristic Y can be determined in advance of shipping the product to a customer. Final product inspection is especially appropriate when the quality dimension is critical and the process produces only the occasional outlier or flier while all other units exhibit very little variation. For example, in the production of aluminum pistons, the diameter of each finished piston (as well as a number of other key characteristics) is measured by an automated gauge after the piston temperature is controlled. Pistons with large or small diameters are scrapped. In such a situation, the costs associated with 100% inspection, including installation and operation of the automated gauge, are warranted due to the high production volume and the critical nature of the product characteristic. Assuming no inspection error, the 100% inspection strategy has the advantage of being able to guarantee that no units with quality characteristic outside the inspection limits will be shipped to a customer.

Final product inspection has a number of significant negative features. The cost of reducing variability by tightening the inspection limits may be very high due to increased rework and scrap costs and lost capacity. Also, the cost of inspection itself may be large if new gauging or

additional labour is required. Measurement or inspection errors will result in increased variability. As a result, given the propensity of people to make inspection errors, most successful applications use automated inspection. As shown in Figure 1, the resultant quality of many of the units passed through our inspection procedure may be just barely inside the cutoff values. As a result, from a loss function perspective (Taguchi, 1986), inspection may be a poor approach since the output may be only marginally better after the inspection procedure. Finally, inspection is applicable to processes with continuous flows only if the production is divided into batches.

One common modification of this strategy is inspection sampling where not every unit is measured. This requires the definition of a lot. Lots are accepted or rejected based on the quality of a sample taken from the lot. Accepted lots are shipped and rejected lots are 100% inspected or otherwise disposed. If we know that lot to lot variation is large and within lot variation is small, then inspection sampling is effective. Thus, using inspection sampling, variation may be reduced by redefining a lot, changing the acceptance criteria, or changing the inspection limits. Compared to 100% inspection, inspection costs are reduced. However, overall variability will not be reduced to the same degree. Note that if the process is stable, then partial inspection is a poor strategy. Deming (Chapter 15, 1986) showed that in this case either no or complete 100% inspection is optimal.

Feed-back Control

Feed-back control is a simple concept that may lead to complex procedures. The idea is to monitor the current output characteristic Y and to make adjustments to the process based on the observed output. By making appropriate adjustments, we compensate for changes in unidentified process inputs, thus reducing the variability in future values of Y . The effect of a simple feed-back control plan is illustrated in Figure 3. Whenever the process output reaches the adjustment limits, the process is re-targeted by making appropriate adjustments. Figure 3 demonstrates the resulting reduction in variability. The effect of feed-back control is determined by the adjustment limits and adjustment procedure.

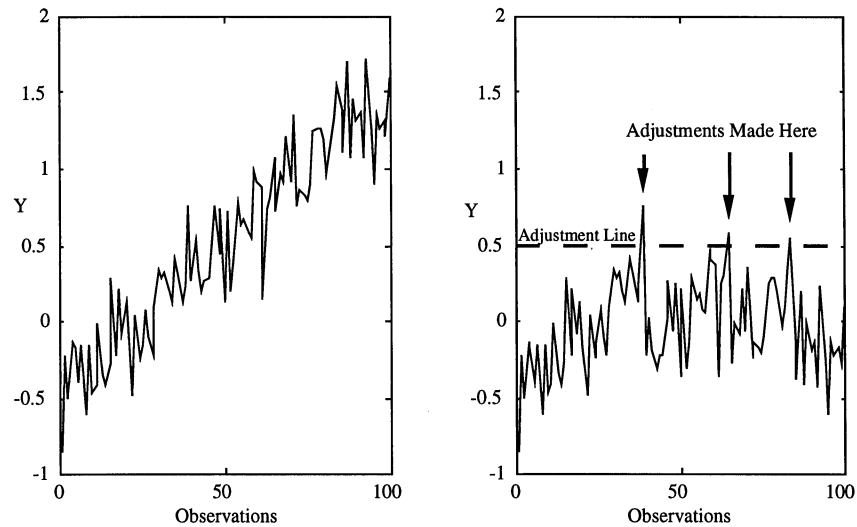

Figure 3: Drift in Process Output Quality

Feed-back control can be successfully applied when three conditions are satisfied. First, the process must be predictable; that is, the past and current output must tell us something about future values. In other words, the process must exhibit structural variation (Joiner, 1994). Examples of structural variation include drift due to tool wear and stratification due to batch to batch variation. Second, there must be a way to re-target the process. Finally, the time to measure the output and adjust the process must be small relative to the rate of change of the process. An existing feed-back control strategy can be altered to reduce variation by addressing one of the three conditions. For example, better knowledge of the nature of the process variation can be used to redesign the adjustment limits.

Feed-back control is used, for example, to reduce variation in the concentration of silicon in molten iron in a foundry. Iron is sampled from the output stream and the concentration of silicon is determined in the sample. Based on the observed concentrations adjustments are made (upstream) to the feed rate of silicon in the melting process. Another common example is the use of setup procedures based on first-off measurements. The major advantage of feed-back control is that it requires little process knowledge. Like final product inspection, it uses measurements on the final product only.

There are a number of drawbacks to feed-back control. A major danger is over adjustment (tampering). If the process is stable, then adjusting on the basis of the output will lead to increased variability. This illustrated in the famous funnel experiment, see Deming, 1986 pp. 327-328. If the pattern of the structural variation is unstable over time, then variation will not be reduced as expected due to inappropriate adjustments. Also, the process measurements and adjustments may be expensive. Finally, due to the feed-back nature of the control, there is an inherent time delay. To identify when an adjustment is required we must first observe some output values that are significantly different from the target value. Thus, feed-back control is always reactive.

There are many ways to monitor the process and decide when to make adjustments. See Tucker, Faltin, and Vander Wiel (1993) for further details. Specific examples include acceptance control charts (Duncan, 1986), Precontrol (Shainin and Shainin, 1989, Juran, 1988). Most feed-back control systems use a function of recent output values, not just the last value, to determine if an adjustment is necessary. If the drift in Y is as regular as shown in Figure 3, we could also base adjustments simply on the time or the number of units processed (or any other cheaply measured variable highly correlated with the output dimension Y).

Reduction of Variation in Process Inputs

As the saying goes “garbage in garbage out.” If there is a large amount of variation in process inputs, then it is difficult to produce consistent output. One improvement approach in this environment is to reduce the variability in one or more inputs. The important input X may be a characteristic of raw materials or component parts, a changing machine setting or any other process input that changes. Reducing variation in inputs corresponds to moving improvement upstream. The problem of reducing variability in X is the analogous to reducing variation in Y . Thus, we have created a recursion in our problem definition, because the input X is the output of some other process. To reduce variability in X we can apply any of the five strategies discussed in this article.

The effect of reducing the variability in an input is illustrated by the variance transmission plots shown in Figure 4. In this example, most of the variation in Y is due to variation in the input

X . As a result, if we reduce the variability in the input X as shown, the variability in the output Y will also be significantly reduced.

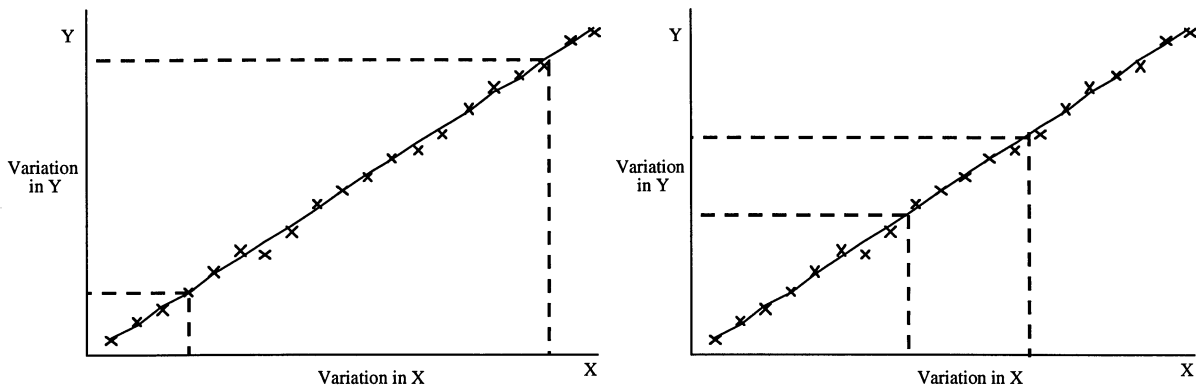

Figure 4: Variance transmission between input X and Output Y

There are three basic conditions necessary for this strategy to work. First, we must be able to identify an input that has a causal influence on the output Y . Thus, a change in X must lead to a change in Y . Second, we must identify an X that is a major source of variation as shown in Figure 4. Third, we must be able to reduce the variation in X .

There are many tools for discovering the identity of such an X . We may use observational studies such as control charts and multi-vari charts or more active approaches such as designed experiments. It is very important that the identified factor X is truly a significant factor influencing the variation in the output.

This approach is proactive. The control of the process is moved upstream which may reduce cost and complexity, and less effort may be needed to monitor the process output Y . An example of this strategy occurred in the machining of the aluminum pistons described above. A variation transmission study identified the piston diameter after an intermediate operation as X , the major source of variation in final piston diameter. The variation of X was reduced by instituting improved operator instructions at the operation and better training of the operators in the use of these instructions.

One difficulty with this strategy is that first we must identify an X , which is both an important contributor to the variation in Y and which is causally related. This may prove arduous

and involves possibly significant study costs. Second, reducing variability in X may be very difficult and/or costly. Third, tightened specifications on X moves the responsibility for control of the process upstream, and possibly outside the influence of local management.

Figure 4 shows a continuously varying input X . However, in many cases X is discrete. For example, X could represent multiple suppliers or multiple machines in parallel processing operations. In this case, reducing variation in X could be accomplished by reducing the number of suppliers or establishing procedures to reduce differences among the suppliers.

Feed-forward Control

Using feed-forward control, we adjust the process in response to measurements made on an input X , anticipating the effect on the output Y . If the measured value of X provides a prediction of the corresponding output Y , feed-forward control can reduce variation in Y by adjusting the process to compensate for different X values. Figure 5 demonstrates the effect of adjusting Y based on knowledge of X and the relationship between X and Y .

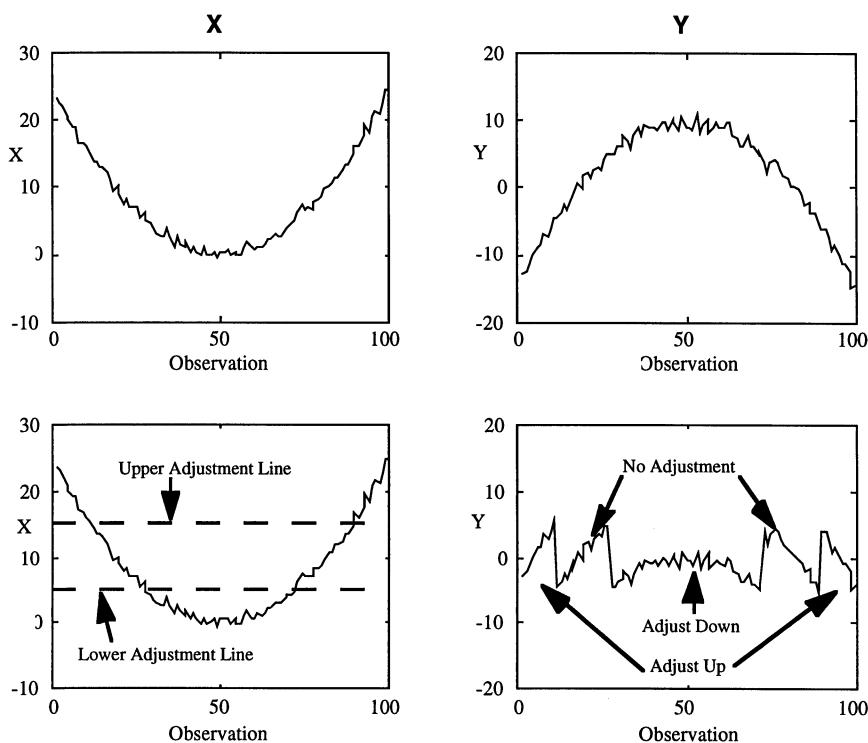

Figure 5: Feed-forward Control

Feed-forward control works under restrictive conditions. First, we must identify an X that is an important source of variation. Second, the relationship between X and Y must be well known and stable over time. Third, we must be able to measure X in a timely way and predict when X will have an effect. Finally, there must be a way to adjust the process to compensate for the changes in X .

Feed-forward control can be very effective if the above conditions are satisfied. A simple example is the use of set-up procedures based on the properties of the raw materials. Another is selective fitting, the technique of sorting and matching component parts to get good assemblies. This procedure has been used to reduce variation in clearance between pistons and cylinder block bore walls by matching piston and bore diameters. Note that this adds additional complexity to the assembly process.

There are substantial costs and risks associated with feed-forward control. Costs arise because we need to determine the relationship between X and Y , measure X , and repeatedly adjust the process when appropriate. As with feed-back control, there is a danger of over adjustment if there is a measurement problem with X or if the relationship between X and Y is not well understood. In addition, repeated process adjustment may be simply impractical or very costly and may introduce other undesired side effects.

Process Desensitization

Desensitization of the process aims to reduce variability by making the process more robust to the variability in process inputs. This is also called parameter design as discussed by Taguchi (1985) and Nair (1992). Desensitizing the process works by identifying and exploiting interactions between important varying inputs X and other normally fixed process parameters. Figure 6 demonstrates how modifying the relationship between Y and X by changing other process parameters results in less variation in Y over the same range of variability in X .

Typically the process settings that yield a more robust process are identified through a designed experiment which uses both X and a set of control factors. The experiment must be designed so that interaction between X and the control factors can be identified.

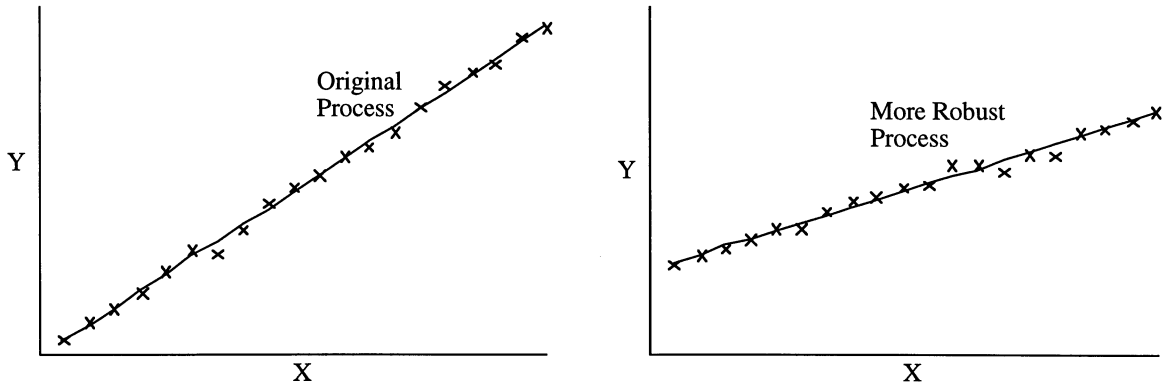

Figure 6: Desensitizing the Process

Process desensitization is a very desirable strategy since once it is complete, no further action is required. Taguchi (1985) cites several examples, including the famous Ina tile case. Another example involved the reduction of variation of sulfur concentration in molten iron where X was the unknown and uncontrollable amount of sulfur in the scrap iron being melted. An experiment identified new settings in the desulfurization process that reduced the within-shift variability in the output molten iron.

It is difficult to predict when desensitizing the process will work. This is one of its great weaknesses. Also, making a process more robust requires a great deal of process knowledge. Determining appropriate settings of the control parameters usually requires expensive designed experiments that may fail to determine settings that lead to improvement. Also, the new process settings may be a more expensive way to run process and require a re-targeting of the process.

In theory, making a process more robust can be accomplished without any knowledge of the factor X , even its identity. Taguchi recommends identifying X (the noise factor) and then conducting an inner-outer array experiment in which X is controlled. An alternative is to define an experimental run as the operation of the process over a period of time sufficiently long to allow the unknown X to vary substantially. Control factors are altered in an organized way for a number of

such runs. The process variability is measured over each run and is then used as the response in the analysis of the experiment. However, without knowing X , we run a significant risk of determining a more robust setting that is only better under the limited operating conditions used in the experiment. It is also more difficult to identify control factors that may be used to reduce the variation when X is not identified.

Examples

In any application, a decision must be made as to which strategy or combination of strategies should be used. To demonstrate the thought process required, we consider two examples. The examples demonstrate that the more you know about the process, the more flexibility there is in choice of strategies. In the first example, all the generic strategies are reasonable. However, the best approach depends on unknown factors, and can not be determined without further study. In the second example, reducing the variation in the inputs was deemed the most cost effective strategy. However, other approaches were potentially feasible.

Example 1: A Multi-batch Process

Suppose we have a process that operates on batches of raw material. A sample of process output is given in Figure 7 where each batch of raw material yields 50 sample points. Clearly, the major shifts in the process correspond to changes in batch of raw material. Given only this information, and the goal of variation reduction what are the possible strategies?

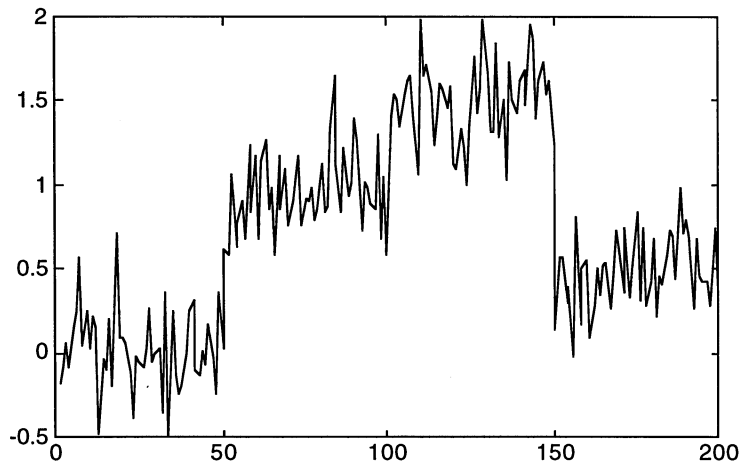

Figure 7: Multi-batch Process Output

If the output is measured on discrete units, then final product inspection coupled with a rework loop will reduce the variability in the output. Because of the large batch to batch variability, lots can be defined based on input batch and sampling inspection can be used to identify discrepant lots. However, in this example, inspection is likely not a good choice because it will provide only minimal improvement unless we are willing to rework many units.

In this example, feed-back control is a good approach. By closely monitor the output Y each time we change batches of raw material, we can estimate the current process mean. Assuming an adjustment mechanism is available, we can then adjust the process to compensate for the batch effect. Feed-back control has the disadvantage that there will be some time after we start a new batch of inputs where we operate the process to determine the magnitude of adjustment required.

Reducing the differences between batches of raw material leads to more consistent batches, thereby creating more consistent output. This is probably the most desirable approach, but will certainly require further study since we do not know what characteristic of the batches is responsible for the variation in Y . That is, we have not identified X .

If we can identify and measure X on each batch, then feed-forward control may be a good choice. If X is a good predictor of Y , and the process target is adjustable, we could compensate

for the batch differences before we use the batch. Note that this avoids the time delay implicit in feed-back control.

Finally, desensitizing the process to variation in batches can also work, but will require an extensive study to determine robust process settings. If we have not identified X , then each run of the experiment will have to include several batches of raw material. The robust settings may not be able to remove the effect of batch difference entirely since, in this example, the differences between batches is large.

Example 2: Crankshaft Machining

Journal diameter is a key product characteristic on machined crankshafts. The machining process is illustrated below in Figure 8. Raw castings are identified by hour, date of casting and mold number. The measurements at the final gauge are monitored informally. If the operator notices a significant number of rejects due to small or large journal diameters, he or she asks for an adjustment in the grinder that produced most of the rejects.

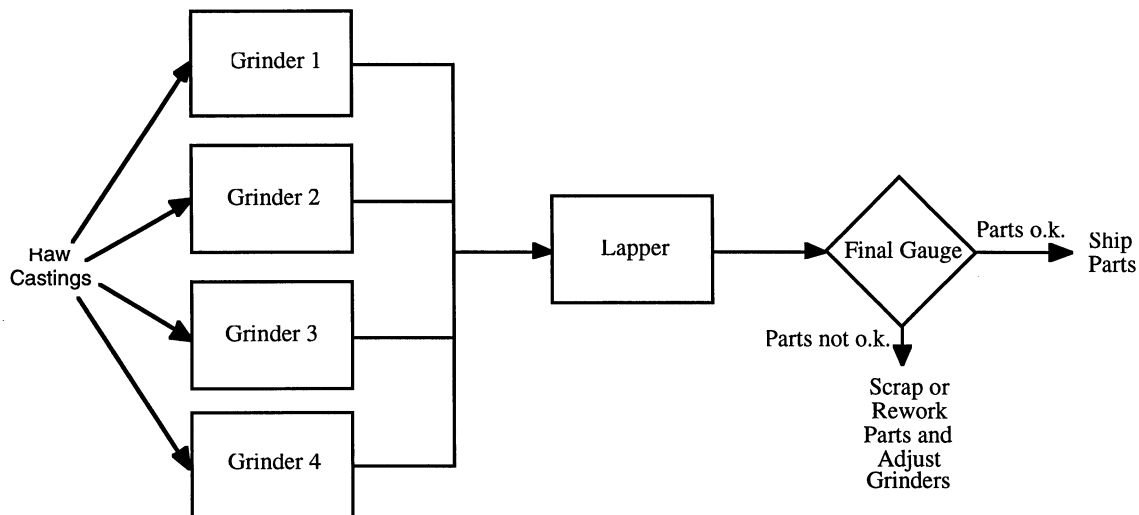

Figure 8: Crankshaft Production Process

The objective is to reduce long term variation in the journal diameters of finished crankshafts. How do we select a strategy?

The first step is to determine current process performance, in terms of stability, structural variation and capability. This requires monitoring process performance at the final stage. Without this knowledge, it is difficult to assess which, if any strategy, is likely to be effective.

The simplest approach is to tighten the inspection limits. The consequence is an increase in scrap and rework and lost capacity, which in this case is considered too expensive. A second possibility is to consider improving the current feed-back control. This involves defining a standardized procedure that all operators will follow that makes better use of the final inspection data. Since changing people's behavior is difficult, and because there is a large number of in-process crankshafts between the grinders and the final gauge, consideration of this choice is postponed. The next step is to identify X, an important source of variability in the journal diameters. A modified multi-vari study (Juran, 1988) was carried out that considered the lapper, the grinders and lot of castings as major potential sources of variability. This study was inexpensive because it involved measuring and recording journal diameters on a purposely selected sample of crankshafts before lapping and at final inspection. The results show large grinder to grinder differences in average diameter before lapping which was transmitted to the final diameter. As a result, the grinders were identified as the major source of variation.

The remaining three strategies can now be considered. The first possibility is to change the control plan on the grinders so that each is targeted to the same value (reduce input variation). The second possibility is to change the transfer process between the grinders and the lappers so that the lapper works on a batch of crankshafts from a single grinder. Then feed-forward control is possible because the lapper can be set to remove more material from batches with larger average incoming diameters. Note that the major purpose of the lapper is to improve surface finish so that this would be a change in function. Another possibility considered was the use of a "smart" lapper that would measure the incoming journal size and change the lapping time accordingly. These feed-forward schemes were both rejected due to high cost. The strategy to desensitize the process due to the variation in after-grind diameter was briefly considered and rejected because there were no control factors in the lapping operation that could be feasibly used.

The elimination process left grinder control as the only feasible strategy. This required a further investigation of the current control plan for the grinder operation. A better feed-back control system using the diameter after grinding was then implemented.

Summary and Conclusions

This article compares and contrasts five variation reduction techniques. We believe these five techniques either singly or in combination encompass all possible reduction methods. The goal of the article is to describe and explain the various methods and to aid the practitioner in making a judicious choice of technique. Figure 9 provides a tree diagram showing the major divisions leading to an appropriate choice. X refers to a significant input and Y refers to the critical output dimension. The process knowledge requirement and potential risks of the different variation reduction methods have been summarized in Table 1.

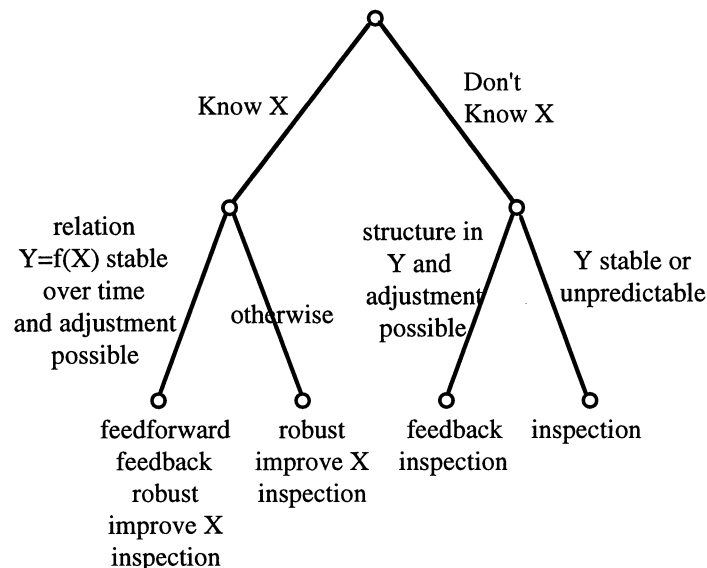

Figure 9: Decision Tree to Determine Appropriate Variance Reduction Strategy

Reduction of variation requires either a change in the process or a change in the control of a process. Adopting final product inspection, feed-back control, reduction of variation in inputs, or feed-forward control leads to a change in the process control plan. Process desensitization, on the

other hand, leads to a change in the process, and does not necessarily effect the control plan. However with a more robust process, it is possible that the control plan rules could be relaxed.

References

- Advanced Product Quality Planning and Control Plan: Reference Manual*, (1994), Automotive Industry Action Group.
- Deming, W. E. (1982), "Out of the Crisis," MIT Center for Advanced Engineering Study.
- Duncan, A.J. (1986), *Quality Control and Industrial Statistics* (5th ed.), Homewood, IL: Richard D. Irwin.
- Joiner B.L. (1994), "Fourth Generation Management: The New Business Consciousness," McGraw-Hill, New York.
- Juran, J.M. (1988), "Quality Control Handbook, 4th edition, McGraw-Hill, New York.
- Nair, V.N. (1992), "Taguchi's Parameter Design - A Panel Discussion," editor, *Technometrics*, Vol. 34, 127-162.
- Shainin D., Shainin, P. (1989), "Pre-Control versus \bar{X} and R charting: continuous or immediate quality improvement?," *Quality Engineering*, Vol. 1, 419-429.
- Taguchi, G., Wu, Y. (1985), Introduction to Off-line Quality Control, Central Japan Quality Control Association.
- Taguchi, G. (1986), Introduction to Quality Engineering, UNIPUB/Kraus International Publications, White Plains, NY.
- Tucker, W.T., Faltin, F.W., Vander Wiel, S.A. (1993), "Algorithm Statistical Process Control: An Elaboration," *Technometrics*, Vol. 35, 363-375.