



Fatigue crack growth analysis using 2-D weight function

A. Jankowiak^a, H. Jakubczak^{a,*}, G. Glinka^b

^aWarsaw University of Technology, Institute of Construction Machinery Engineering, Narbutta 85, 02-524 Warsaw, Poland

^bUniversity of Waterloo, Department of Mechanical and Mechatronics Engineering, Waterloo, Ontario, Canada N2L 3G1

ARTICLE INFO

Article history:

Received 17 September 2008

Received in revised form 29 January 2009

Accepted 18 February 2009

Available online 1 March 2009

Keywords:

Stress intensity factor

2-D weight function

Arbitrary crack shape

Arbitrary stress distribution

Crack growth

ABSTRACT

A method for crack growth analysis of planar cracks under arbitrary Mode I loading is presented in the paper. The method is based on the point-load (2-D) weight function used for the calculation of stress intensity factors. An algorithm for the analysis of fatigue crack growth of planar cracks, and validation results supporting the entire methodology is also discussed. Application examples of the proposed method for crack growth analysis under arbitrary Mode I stress fields are presented as well.

© 2009 Elsevier Ltd. All rights reserved.

1. Introduction

Mechanical and structural components contain often crack-like defects or cracks initiated at notches under service cyclic loading. Cracks can initiate sub-surface (embedded elliptical-like cracks) or at the surface and have most often a semi-elliptical shape (surface cracks). The surface cracks are very common for welded joints of structural components.

In order to determine the time spent on the stable fatigue growth of such cracks the crack growth analysis needs to be carried out. Crack growth analyses in engineering practice are very often carried out for Mode I crack loading, i.e. for normal stress applied to the crack surface. One of the most important issues in the crack growth analysis is the calculation of the stress intensity factor (SIF). The problem is quite simple if the stress applied to the crack surface is uniform or symmetrical with respect to the crack axis [7,8]. However, the problem gets complicated in the case of 2-D non-uniform stress distribution. Moreover, in the case of geometrically complex crack shapes and machine or structural components certain simplifications are necessary resulting in the approximation of actual cracks by standard elliptical or semi-elliptical shapes. This may result in inaccurate (and usually conservative) residual life predictions.

The determination of SIFs and the two-dimensional analysis of fatigue growth of planar cracks under non-uniform stress distribution is possible only by using the finite element (FEM) or boundary element (BEM) method. Despite some advantages both methods

require experience and are time consuming in the case of the fatigue crack growth analysis.

The point-load weight function developed by Glinka and Reinhardt [1,9] enables calculation of stress intensity factors for planar convex cracks under any Mode I stress distribution. Application of the method, discussed below, to fatigue crack growth analysis may significantly reduce the calculation time. The method makes possible to calculate stress intensity factors at arbitrarily selected number of points on the actual crack contour. Crack extensions are then calculated for each of these points and the new crack shape is determined. The process is repeated on cycle-by-cycle basis until the final crack dimension is achieved. The number of repetitions determines the fatigue crack propagation life in cycles.

2. Point-load weight function (WF2D)

The two-dimensional point-load weight function $m_A(x,y)$ represents the stress intensity factor at an arbitrary point A on the crack front, induced by a pair of unit forces, $F = 1$, applied to the crack surface at point $P(x,y)$, presented in Fig. 1. In order to determine the SIF at the point A on the crack front induced by a two-dimensional stress field $\sigma(x,y)$ the product of the stress field $\sigma(x,y)$ and the weight function $m_A(x,y)$ needs to be integrated over the entire crack surface area Ω [7]:

$$K_A = \int_{\Omega} \int \sigma(x,y) \cdot m_A(x,y) dx dy \quad (1)$$

The point-load weight function $m_A(x,y)$ was derived from the approximate equation proposed by Oore and Burns [6] – see notation in Fig. 1.

* Corresponding author. Tel.: +48 809 098 494.

E-mail address: Hieronim.Jakubczak@simr.pw.edu.pl (H. Jakubczak).

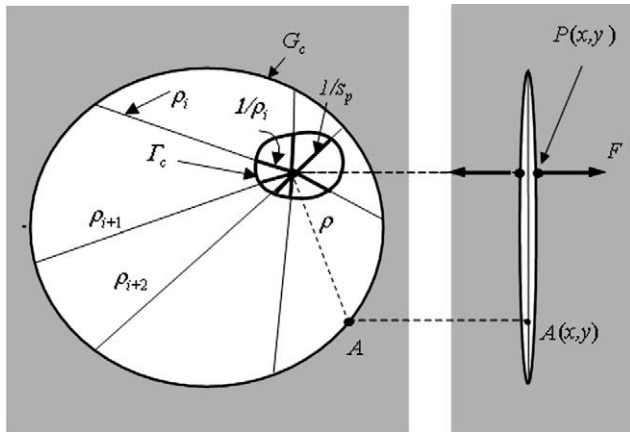

Fig. 1. Point load (2-D) weight function notation.

$$m_A(x,y) = \frac{\sqrt{2}}{\pi \cdot \rho^2 \cdot \sqrt{\int_{\Gamma_C} \frac{d\Gamma_C}{\rho_i^2}}} \quad (2)$$

It is quite difficult to drive the point load weight function (2) in a closed form for a specific configuration. Only a limited number of solutions and mostly for cracks in infinite bodies are known contemporary.

It is worth noting while calculating the weight function (2) that the line integral represents the arc length, Γ_C , of the crack contour inverted with respect to the point $P(x,y)$ – Fig. 1. The inverted contour Γ_C , shown in Fig. 1, can also be understood as the locus of inverted radii $1/\rho_i$. It can also be proved that inverted contours form circles in the case of straight and circular crack contours. In other words, the inverted contour is a circle in the case of cracks with a constant curvature. Subsequently, the weight function (2) makes it possible to derive closed form weight functions for a variety of straight and circular crack configurations [1,7].

The weight function properties mentioned above can also be used for the SIF calculation and analysis of fatigue crack growth of irregular shape cracks. In such a case it is necessary to approximate the crack contour by rectilinear segments (Fig. 2). Stress intensity factors are calculated at points $A(x,y)$ in the middle of each segment. Therefore approximation of the crack contour requires some caution so that angles γ between adjacent linear segments are as close as possible to 180° . The requirement concerning the maximalisation of angles γ helps to determine the optimum number of linear segments. The inverted contour, Γ_C , is calculated

as the sum of all inverted contours, Γ_{Ci} , corresponding to each linear segments of the crack contour:

$$\Gamma_C = \sum_{i=1}^n \Delta\Gamma_{Ci} \quad (3)$$

where

$$\Delta\Gamma_{Ci} = \frac{1}{2s_{pi}} \cdot \Delta\alpha_i \quad (4)$$

In the case of embedded cracks in finite bodies the external boundary effect has to be accounted for as well. Glinka and Reinhardt [1] proposed the following formula for that purpose:

$$m_A(x,y) = \frac{\sqrt{2}}{\pi \cdot \rho^2} \cdot \frac{\sqrt{\Gamma_C + \Gamma_B}}{\Gamma_C} \quad (5)$$

The arc length, Γ_B , represents the length of the external boundary contour inverted with respect to the point $A(x,y)$ – Fig. 2. The inverted external contour, Γ_B , can also be looked at as the locus of inverted radii $1/r_k$. The inverted contour, Γ_B , is calculated as the sum of inverted contours, Γ_{Bk} , of all linear segments of the external boundary contour:

$$\Gamma_B = \sum_{k=1}^m \Delta\Gamma_{Bk} \quad (6)$$

where

$$\Delta\Gamma_{Bk} = \frac{1}{2s_{Ak}} \cdot \Delta\beta_k \quad (7)$$

Analyses described in Refs. [1,3] revealed that accuracy of approximation of the external boundary contour is not as important as that of the crack contour. Calculation of the stress intensity factor for any point $A(x,y)$ on the crack contour needs summation of all products of the point-load weight function, $m_A(x,y)$, and loads $F_j(x,y)$, resulting from the stress field $\sigma(x,y)$ acting over the elemental crack surface area, $dxdy$:

$$K_A = \sum_{j=1}^l F_j(x,y) \cdot m_A(x_j, y_j) \quad (8)$$

where

$$F_j(x,y) = \int_{x_j - \frac{dy}{2}}^{x_j + \frac{dy}{2}} \int_{y_j - \frac{dx}{2}}^{y_j + \frac{dx}{2}} \sigma(x,y) \cdot dxdy \quad (9)$$

Stress intensity factors determined using the general expression (8) coincides fairly well with results acquired from the finite element method [9].

3. Crack growth analysis using the integration algorithm WF2D

If planar cracks are subjected to a non-uniform stress distribution, $\sigma(x,y)$, they may grow non-symmetrically, thus it is not enough to analyze the crack growth in two directions, x and y only, as it is the case of symmetric crack shapes and symmetric stress distributions. For non-uniform stress distribution crack extensions have to be determined for a sufficient number of points along the crack contour.

The method presented below is based on the point-load (2-D) weight function, since it allows for the calculation of SIFs at arbitrarily points along the crack contour. As it was described above, the actual crack contour is replaced by a number of rectilinear segments, and SIFs can be calculated at midpoint, $A_i(x,y)$ of each of them.

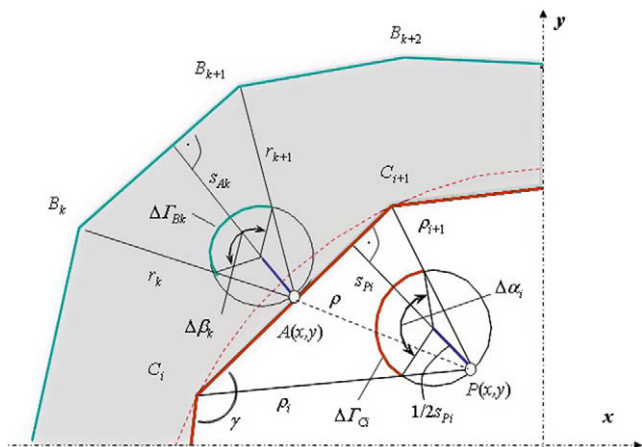

Fig. 2. Determination of the 2-D weight function for approximated contours of the crack and external boundary.

Having calculated SIFs at points $A_i(x,y)$, the crack extension (increment) Δa_i for each segment can be calculated based on crack growth rate data and effective stress intensity range, ΔK_{A_i} , corresponding to the current applied loading cycle. For the Paris' fatigue crack growth law the crack increment at point $A_i(x,y)$ is calculated as

$$\Delta a_i = \Delta N \cdot C \cdot (\Delta K_{A_i})^n \quad (10)$$

where C and n are material constants describing the fatigue crack growth rate, da/dN .

It is assumed that increment Δa_i describes the magnitude of a parallel shift of the i th linear segment of the crack contour due to the application of ΔN loading cycles (Fig. 3). For the cycle-by-cycle crack growth analysis the increment is $\Delta N = 1$, however, it can be increased for faster analysis without losing too much from the accuracy [4] of fatigue crack growth prediction.

The accuracy of the proposed analysis method depends on several factors. An important factor is the accuracy of the piecewise linear approximation of the crack contour. It is obvious that the increase of the number of linear segments results in a better accuracy of the analysis. However, large number of linear segments on the other hand results in a substantial increase of the computing time. Since the basic goal of the proposed procedure is aimed at shortening and simplification of fatigue crack growth life assessment procedure for cracks subjected to complex stress distributions, a compromise must be found.

In order to find a reasonable approximation method, an extended analysis was carried out [5] for various crack/load configurations. Since the analysis was performed for idealized crack shapes such as: an elliptical, semi-elliptical, and corner crack the crack contour was approximated with segments of equal length, and the research was aimed at finding sufficient number of segments. Several observations were drawn from that examination and they are summarized below.

First observation was that the coarser approximation of the crack contour the shorter was the predicted fatigue crack growth life. It was observed that using more than 30 segments (31 points) for the crack contour approximation of semi-circular crack with the aspect ratio of $a/c = 1$ and the uniform tensile stress distribution would not significantly improve the accuracy of predicted fatigue lives (Fig. 4). More than 30 linear segments resulted in only small increase of the predicted life in comparison with the life predicted on the 30 linear segments approximation. On the other hand, the computing time for the same crack begins to increase significantly (faster) when the number of segments is greater than 20. This led to the conclusion that for the crack shape and loading

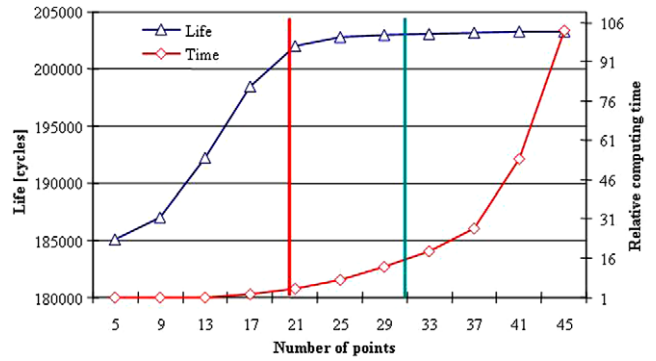

Fig. 4. Influence of the γ angle on the predicted fatigue crack growth life of semi-elliptical surface crack.

distribution being examined from 20 to 30 segments were sufficient for reasonably accurate representation of the actual crack contour.

Other cracks examined such as the elliptical and corner crack had shown similar dependence and the proposed number of segments for their approximation were 36–60 and 9–15, respectively. The important observation was that similar effects were observed for non-uniform stress distributions, which makes the observations more general in nature.

In the case of irregular crack shapes the number of segments itself is not of primary importance as far as the accuracy of the crack contour approximation is concerned. However, the increase of the number of linear crack contour segments results in larger values of the angle γ between adjacent segments (Fig. 3). It appears that the angle γ can be considered as a more general parameter defining the accuracy of the crack or external contour approximation. The angle γ is a convenient parameter because it can be easily and quickly evaluated, and also it can be applied as an accuracy parameter to approximate any crack shape. It is worth to note that if the requirement of the constant angle γ is applied an unequal linear crack contour segments need to be used.

In order to select appropriate value of the angle γ , resulting in acceptable accuracy of the crack contour approximation several types of cracks under uniform stress distribution were analyzed. The analysis has shown that the preferable value of the angle γ can be needs to be at least 170° . For semi-circular cracks with the aspect ratio $a/c = 1$ that value of angle γ yields approximately 20 equal segments necessary for the approximation of the entire crack contour. Increasing the angle above 174° (ca. 30 segments) only slightly improves the accuracy (1–2%) of the predicted life (Fig. 5) but significantly increases the computing time.

Several other factors affecting the accuracy of the analysis were examined earlier [4] such as

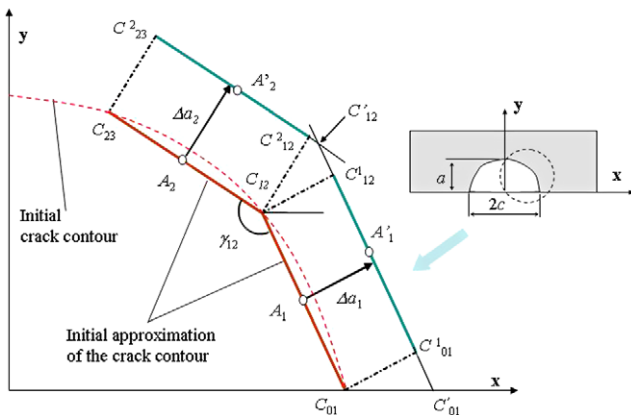

Fig. 3. The idea of the crack growth analysis by using the point load weight function.

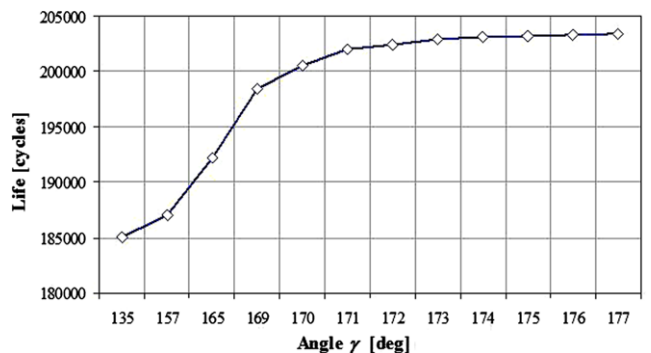

Fig. 5. The effect of the angle γ on predicted fatigue life for a semi-elliptical crack.

1. The effect of the increase of the number of linear segments during the crack growth simulation by applying new approximations (increased number of linear segments),
2. Partitioning of long linear segments which evolved due to uneven crack extension and fitting them to the theoretical crack contour.

The analyses performed for various crack shapes and stress distributions revealed that the predicted life was only few percent longer than that one obtained for constant number of segments, whereas the calculation time increased significantly.

The algorithm for crack growth analysis using the 2-D weight function is as follows:

1. Determine the location of the crack or crack-like defect in a component, and define the plane of the prospective crack growth (Fig. 6). The plane can be assumed as perpendicular to the principal stress component S_1 .
2. Replace the actual crack contour by a number of linear segments.
3. Calculate the SIFs at mid point $A_i(x,y)$ of each linear segment.
4. Calculate the crack extension (increment) Δa_i for each segment based on crack growth rate data and the effective stress intensity range, ΔK_{A_i} , induced by current loading cycle.
5. Apply parallel translation of each linear segment by the calculated crack increment Δa_i .
6. Construct the new crack contour and locate positions of points $A_i(x,y)$ for each segment. It should be noted that after several subsequent crack increments the linear crack contour segments adjacent to the external boundary elements may vanish.
7. Repeat steps 3 through 6 until the crack growth analysis limiting condition is reached. The crack growth can be considered complete after reaching pre-defined final crack dimension or by exceeding the fracture toughness of the material or after elapsing required number off loading cycles. The number of cycles, N , accumulated to reach one of the limiting conditions determines the fatigue crack propagation life of the analyzed component.

4. Validation of the crack growth procedure

An extensive validation of the proposed procedure concerning fatigue crack growth analysis of two-dimensional cracks was carried out. The results were compared with those obtained from the FALPR fatigue analysis program described in Ref. [2]. The FALPR program uses 1-D weight function method for calculating stress intensity factors, which in the case of planar cracks is limited to

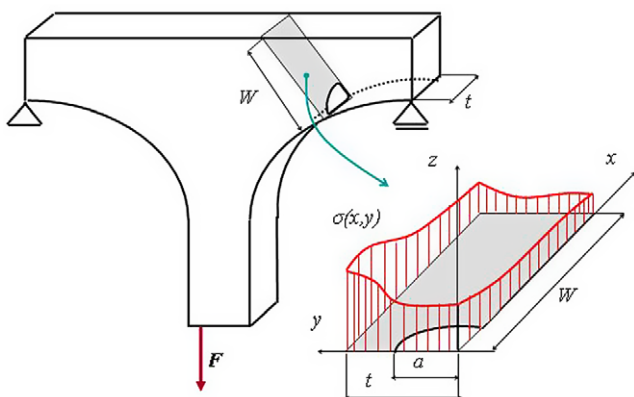

Fig. 6. Defining the prospective crack growth plane and the Mode I stress distribution.

only one-dimensional stress distributions. Therefore the comparisons were performed for selected planar cracks (semi-elliptical and corner cracks) under stress distributions defined by 1-D mathematical formula. The results obtained for semi-elliptical cracks are described below.

The comparisons were performed for a semi-elliptical crack with initial aspect ratios $a/c = 0.2-2.0$, and for three different stress distributions, i.e. uniform, linearly decreasing along the symmetry axis of the crack, and linearly increasing along the same axis. The through thickness fatigue crack growth was analyzed in the plate of thickness $t = 12$ mm and finite width of $2w = 200$ mm and subjected to constant amplitude loading. The crack contour was in all cases approximated by 20 segments (21 points), ensuring sufficient accuracy of the fatigue life estimation. The fatigue life, N , defined as a number of cycles necessary to grow the crack from its initial size of $a_i = 1$ mm to the final crack size of $a_f = 9.6$ mm. The varying aspect ratio, a/c was accounted for in the analysis as well. The results are summarized in Figs. 7 and 8.

The fatigue lives calculated for the same initial crack dimensions were usually shorter by approximately 10–20% than those obtained from the FALPR program. One of possible reasons of such a discrepancy is that in the case of linear segments adjacent to the free surface points $A_i(x,y)$, where the SIF was calculated, were slightly below the surface (x axis) whereas the SIF calculated by the FALPR program using 1-D weight function was calculated exactly at the surface point. This can also be seen in Fig. 8 showing the final crack aspect ratio a/c evolution obtained from the FALPR program and the proposed method using the 2-D weight function.

The results obtained for the uniform and linearly decreasing along the symmetry axis stress distributions were very close to those obtained from the classical method. In the case of the linearly

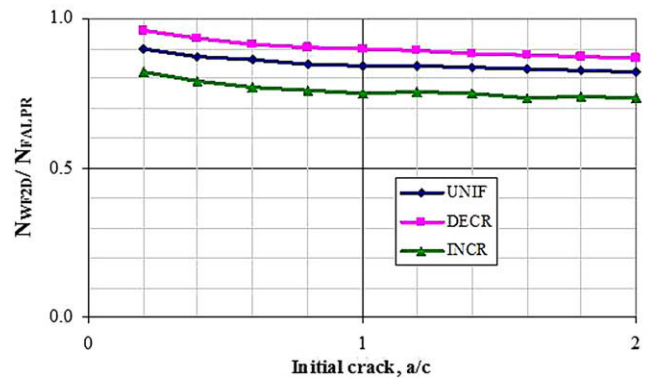

Fig. 7. Predicted relative fatigue crack growth lives for semi-elliptical crack with an initial aspect ratio of $a/c = 0.2-2.0$.

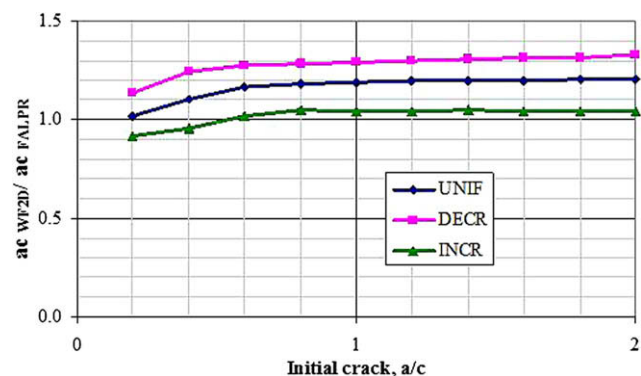

Fig. 8. Predicted relative final aspect ratio for semi-elliptical crack having initial crack aspect ratios $a/c = 0.2-2.0$.

increasing along the symmetry axis stress distribution the difference between results obtained from the two methods was more distinct. This is the case where the SIF at the surface point of semi-elliptical crack is smaller than that one at the deepest point; hence the FALPR program predicts slower crack growth along the surface than the proposed method.

The comparisons presented above indicate that fatigue lives predicted according to the proposed method were conservative by several percent in comparison to the FALPR predictions.

5. Application examples

5.1. An embedded oval crack in a finite thickness plate

To present the capability of the developed method based on the point load weight function (WF2D) some examples of crack growth analysis are presented below. An example set of results obtained for an embedded oval crack (similar to deformed elliptical crack) under uniform stress distribution is shown in Fig. 9. For a better visualization of results the analysis was performed using coarse crack contour approximation.

One may observe that the initial oval-shape crack has been transformed into to a penny-shape crack which indicates that the magnitude of the stress intensity factor along the crack front (at mid points of linear segments) varied and it was particularly visible in the case of the initial crack geometry. The variation of the SIF along the crack front for several crack sizes is shown in Fig. 10. The difference between the smallest and the largest SIF values calculated along the initial crack contour was approximately 40% whereas it was only about 2% in the case of the final (last registered) crack contour. The smallest values of SIFs along the initial crack contour were observed at points located in regions with the largest crack contour curvature.

5.2. A semi-elliptical crack in a finite thickness plate

The example discussed below illustrates application of the proposed method to a fatigue crack growth analysis of a semi-elliptical crack (Fig. 11) in a plate of finite thickness $t = 12$ mm and finite width of $2w = 100$ mm. The initial crack dimensions were: $a = 4$ mm and $c = 6$ mm. The distribution of the stress normal to

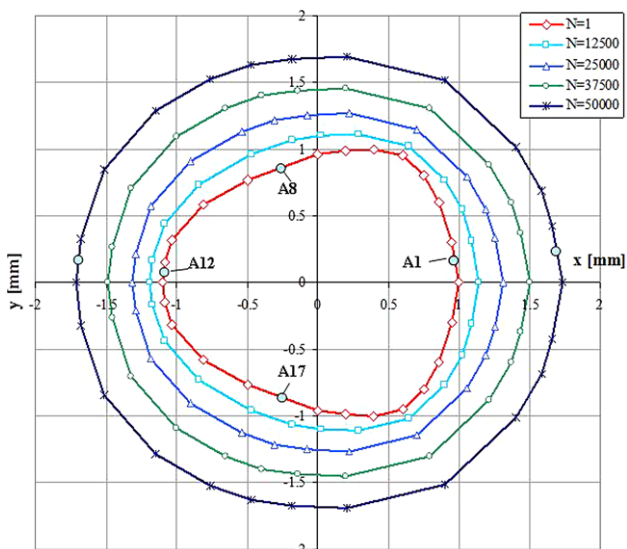

Fig. 9. Evolution of the crack front geometry during fatigue growth of an embedded oval crack.

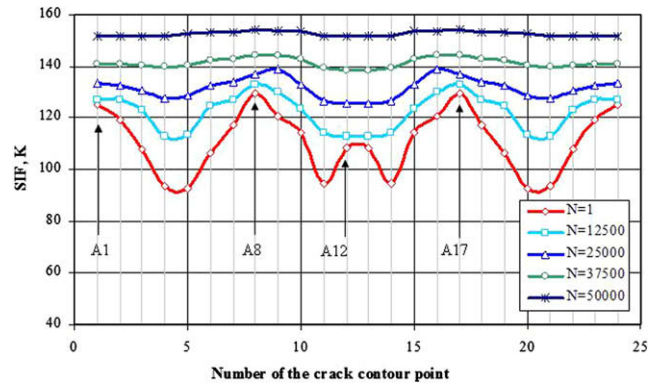

Fig. 10. Variation of the SIF magnitude along the crack front at various numbers of elapsed loading cycles.

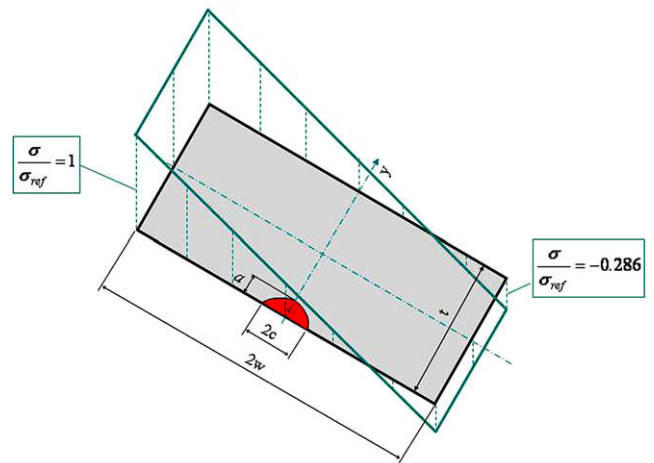

Fig. 11. An example of a semi-elliptical crack under non-uniform stress distribution.

the crack surface is shown in Fig. 11. For such case the fatigue crack growth life assessment can be performed using methods based on the 1-D weight function only if the actual stress distribution is can be approximated the uniform one. Since conservative assessments are usually preferable in engineering practice one may use the uniform stress distribution as an approximation with the characteristic magnitude equal to the maximum stress, i.e. $\sigma = \sigma_{ref}$. The other possibility is to use a uniform stress distribution with characteristic magnitude equal to the average stress, i.e. $\sigma = \sigma_{avg}$, which in the analyzed case is $\sigma_{avg} = 0.357 \sigma_{ref}$.

The fatigue crack growth analysis was subsequently carried out for using the actual and both uniform stress distributions. The coarse crack contour approximation was applied in the analysis. The initial and final crack contour shapes are shown in Fig. 12. It can be noted that the final crack shapes obtained under the two uniform and the actual stress distribution are were almost the same but the final position of the crack grown under the actual stress distribution is was shifted to the left hand side, i.e. to the region of the high stress understandably.

The fatigue crack growth live, defined as the number of cycles necessary to grow the crack up to the depth equal to 80% of the plate thickness, and obtained under the uniform stress distribution with the characteristic stress being equal to the maximum stress, i.e. $\sigma = \sigma_{ref}$ consisted of only 6% of the fatigue crack growth life obtained under the actual distribution. In the case of the uniform stress distribution, having the characteristic stress equal to the

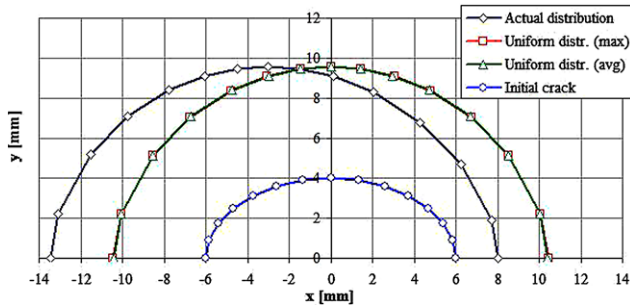

Fig. 12. Examples of the initial and final crack contours (semi-elliptical crack).

average stress, i.e. $\sigma = \sigma_{avg}$ the fatigue life was longer and consisted of 115% of the life obtained under the actual stress distribution.

5.3. A penny-shape crack in a spring

Potential capabilities of the proposed method concerning the assessment of fatigue crack growth lives of cracked bodies was verified by applying it to a real case of an internal flaw in a spring wire. The flaw location and the Mode I stress distribution in the potential crack plane are shown in Fig. 13. The diameter of the initial circular crack was 0.02 mm. The stress distribution was estimated using standard theoretical expressions appropriate for helical springs.

The initial crack contour was approximated with 32 linear segments of equal length and the component cross-section boundary was approximated with 16 linear segments. The crack growth simulation was carried out for a constant amplitude loading and it was continued until the crack contour reached the external body contour, i.e. the free surface.

The evolution of the crack front shape, obtained in due course, is shown in Fig. 14. One may note that the crack growth was faster in the direction towards the free surface so the final crack extension was 70% larger towards the free surface than into the interior of the wire cross-section. The fatigue crack growth rate was relatively high for segments approaching the free surface. The predicted fatigue life coincided fairly well with the observed service life of the actual component.

The examples presented above illustrate potential applications and capabilities of the proposed method in fatigue crack growth life assessment of cracked components containing convex cracks subjected to the Mode I stress distribution. It is also important to

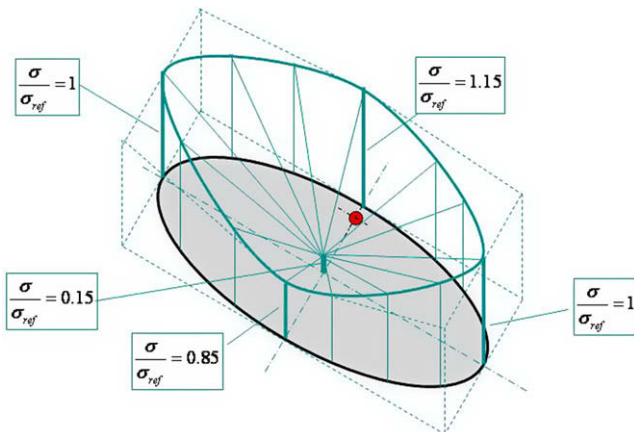

Fig. 13. Location of the penny-shape crack-like internal flaw in the spring wire cross-section and the stress distribution in the critical cross-section.

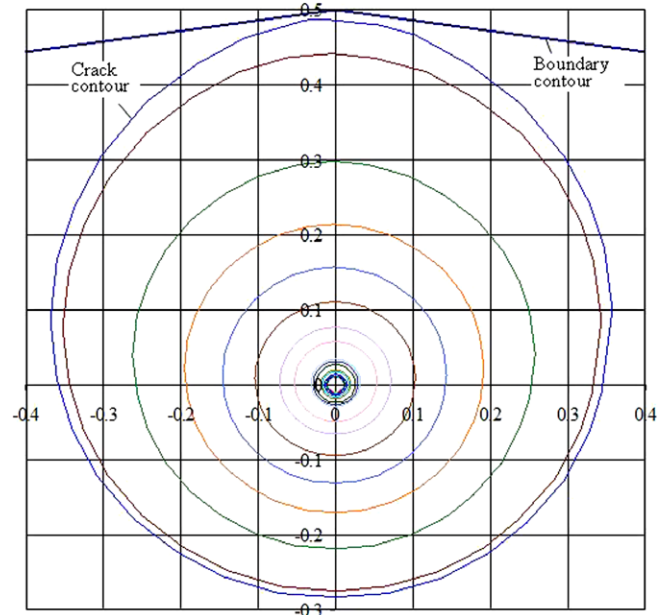

Fig. 14. Predicted crack front contours of the initially penny-shape crack.

note that the actual cracks of irregular geometry and subjected to arbitrary 2-D stress distributions do not have to be approximated by equivalent standard elliptical, semi-elliptical or corner quarter-elliptical cracks as it is in the case of methods using 1-D weight functions. It is also worth noting that the computation time necessary for the simulation of the fatigue crack growth of planar cracks requiring a few million repetitions (loading cycles) is substantially shorter than that one needed for FEM or BEM based fatigue crack growth analyses. The simulation of the fatigue crack growth in the spring wire resulted in the final fatigue life of 58 million cycles and it required ca. 12 h CPU time on a computer with 2 GHz clock. The calculations were carried out on the block-by-block method (1 block = 1000 cycles), i.e. the calculation process had to be repeated 58 thousand times. In the case of the FEM or BEM based analyses it would require re-meshing the entire problem also 58 thousand times!

6. Conclusions

The method of fatigue crack growth analysis based on the SIF calculations obtained from the point-load weight function has been presented in the paper along with examples of its application. The method can be used for fatigue crack growth life assessment of mechanical components containing convex planar cracks or crack-like defects subjected to arbitrary Mode I stress distribution. The fatigue crack growth assessment requires definition of the prospective crack plane in a component and the knowledge of the Mode I stress distribution over that plane. The stress distribution can be obtained for an un-cracked body and independently of the fatigue crack growth analysis. The stress distribution can be determined analytically or numerically depending of the complexity of the configuration to be analyzed. The method is applicable to cracks and the cross-sections of arbitrary but convex geometry subjected to arbitrary Mode I stress distribution.

One of the important elements of the proposed method is the approximation of the actual crack contour with a series of linear segments. The studies carried out up to date have revealed that the best results regarding the accuracy of the SIF and fatigue crack growth life estimations were obtained when the crack contour approximation was achieved with a constant angle γ between

adjacent linear segments. Acceptable accuracy was achieved when the angle γ between adjacent segments was at least 170° .

In most cases the predicted fatigue crack growth lives were conservative by 10–20% in comparison with simulations using the 1-D weight functions and resulting approximations.

The proposed method enables prediction of crack growth lives in CPU times comparable to those needed only for the calculation of handbook classical SIF solutions therefore it is much less time consuming than the FEM/BEM numerical methods.

References

- [1] Glinka G, Reinhardt W. Calculation of stress intensity factors for cracks of complex geometry and subjected to arbitrary nonlinear stress fields. *Fatigue and fracture mechanics*, vol. 31. West Conshohocken (PA): ASTM STP 1389; 2000. p. 348–70.
- [2] Jakubczak H, Glinka G. Program FALPR for fatigue crack growth analysis. Ontario (Canada): Stress and Fatigue-Fracture Design, Inc.; 1995–2008.
- [3] Jakubczak H, Jankowiak A. Mode I stress intensity factors for cracks in arbitrary stress fields. *Mach Dyn Prob* 2003;27(4):7–16.
- [4] Jankowiak A. Analysis of crack growth using the two dimensional weight function. PhD thesis, Warsaw University of Technology; 2007 [in Polish].
- [5] Jankowiak A, Jakubczak H. Crack contour approximation for life assessment based on 2-D weight function. *Mach Dyn Prob* 2006;30(2):54–62.
- [6] Oore M, Burns DJ. Estimation of stress intensity factors for embedded irregular cracks subjected to arbitrary normal stress fields. *J Press Vess Technol ASME* 1980;102:201–11.
- [7] Shen G, Glinka G. Weight functions for a surface semi-elliptical crack in a finite thickness plate. *Theor Appl Fract Mech* 1991;15(2):247–55.
- [8] Tada H, Paris P, Irwin G. *The stress analysis of cracks handbook*. 2nd ed. St. Louis (MO): Paris Production Inc.; 1985.
- [9] Wu Z, Jakubczak H, Glinka G, Molski K, Nilsson L. Determination of stress intensity factors for cracks in complex stress fields. *Arch Mech Eng* 2003;L(1):41–67.