

MME Standard Operating Procedure (SOP)

Name	<ul style="list-style-type: none"> Spark Depo Techncoat ESD Machine
Description	<ul style="list-style-type: none"> Commercial variable parameter ESD machine
Location	<ul style="list-style-type: none"> E3-2107 "Welding Lab"
SOP Creation Date	<ul style="list-style-type: none"> 2015-03-18
SOP Created By	<ul style="list-style-type: none"> Stephen Peterkin
SOP Revision Date	<ul style="list-style-type: none"> 2015-04-06
SOP Revised By	<ul style="list-style-type: none"> Stephen Peterkin
SOP Location	<ul style="list-style-type: none"> inv.mme.uwaterloo.ca
Manual Location	<ul style="list-style-type: none"> E3-2107 "Welding Lab"
Equipment Owner	<ul style="list-style-type: none"> Professor Norman Zhou (x36095) & Huys Industries
Authorized Trainers	<ul style="list-style-type: none"> Joyce Koo, Foss Jiao, Stephen Peterkin and Dominic Leung
Support Technicians	<ul style="list-style-type: none"> Dominic Leung



Significant Hazards	<ul style="list-style-type: none"> Light <ul style="list-style-type: none"> Weak UV radiation from the electrode sparks Weak UV radiation from red hot metals Burns <ul style="list-style-type: none"> Operating electrode tips reach red hot temperatures Fumes <ul style="list-style-type: none"> Some metals may be rapidly oxidized or vaporized during deposition forming toxic vapors Shielding Gas <ul style="list-style-type: none"> Asphyxiation via oxygen deprivation Noise <ul style="list-style-type: none"> Extended use of depending on the applicator can cause hearing damage
Administrative Controls	<ul style="list-style-type: none"> Scheduling of ESD depositions shall be scheduled amongst the authorized personnel Only authorized personnel shall operate, maintain or service the ESD Machine Reduce extended depositions to prevent fatigue, eye damage and hearing damage Depositions using the shielding gas is always to be done in pairs Always run the lab ventilation fan when depositing
Engineering Controls	<ul style="list-style-type: none"> Equipment design prevents short circuit discharges while the applicator is not rotating / vibrating Equipment discharge and resistance requirements prevents electrocution during operation

PPE Required	<p>Typical operating procedures and papers on ESD stress that there are little to no required PPE requirements</p> <ul style="list-style-type: none"> • Eye protection is required during ESD <ul style="list-style-type: none"> ○ Clear safety glasses are the minimum to spectate the ESD equipment ○ Brazing goggles or tinted glasses are highly when operating the equipment ○ Shades beyond 5 may impair vision during deposition and are not recommended • Gloves are to be worn to protect from sparks during deposition as well as prevent burns from handling hot substrates and electrodes post deposition • Long sleeves or lab coats are required to protect wrists and arms from sparks and burns resulting from deposition and contact with hot substrates / electrodes • Hearing protection can be used if loud applicators are being utilized for extended periods of time
Relevant Standards and Codes	<ul style="list-style-type: none"> • none
Relevant MSDS	<p>All MSDSs can be found at msds.mme.uwaterloo.ca</p> <ul style="list-style-type: none"> • Argon Compressed gas • LECO diamond spray
Accident Procedure	<ul style="list-style-type: none"> • All accidents are to be reposted to the supervisor as soon as possible <ul style="list-style-type: none"> ○ Treat minor incidents with First Aid kits or contact UW Health services 599-888-4096 x84096 ○ Contact Dr. Joyce Koo or Professor Norman Zhou ○ Complete incident report • In the event of serious injury / illness Call 911 <ul style="list-style-type: none"> ○ Also contact campus police services 519-888-4911 or x22222 ○ Complete incident report
Emergency Shutdown Procedure	<ul style="list-style-type: none"> • Injury <ul style="list-style-type: none"> ○ Turn off the SparkDepo Machine using the power ON / OFF switch ○ Follow accident procedure ○ Complete incident report • Fire <ul style="list-style-type: none"> ○ Turn off the SparkDepo machine if safe to do so <ul style="list-style-type: none"> ▪ Disconnect the power to the machine if safe to do so and necessary ▪ Turn off the exhaust fan to the lab if safe to do so ▪ Exit the area and assemble outside as stated in the Building Emergency Plan ▪ Access fire extinguisher if the fire is small enough ▪ Fire extinguisher located on the wall in the corridor outside the lab ▪ Activate wall mounted fire alarms ▪ Report any information about the fire to the UW Police and Fire Department

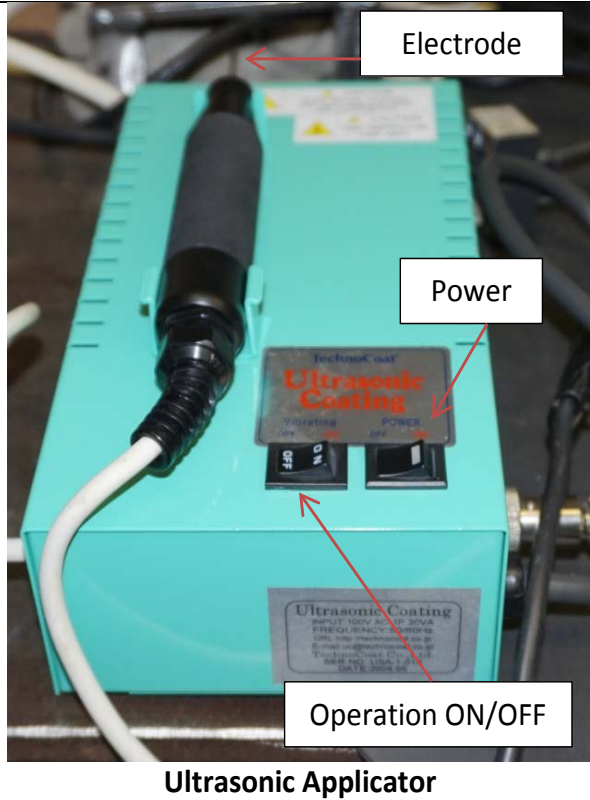
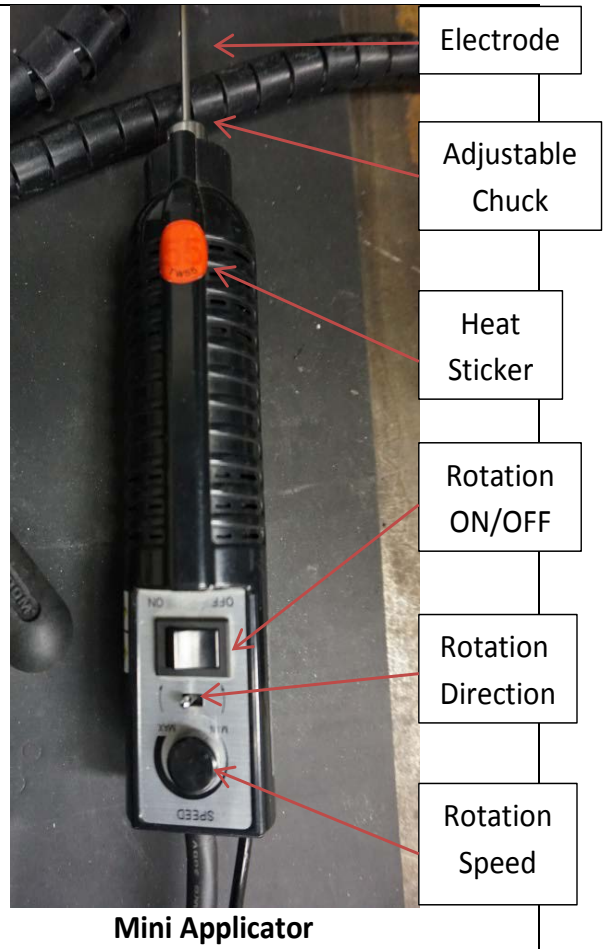
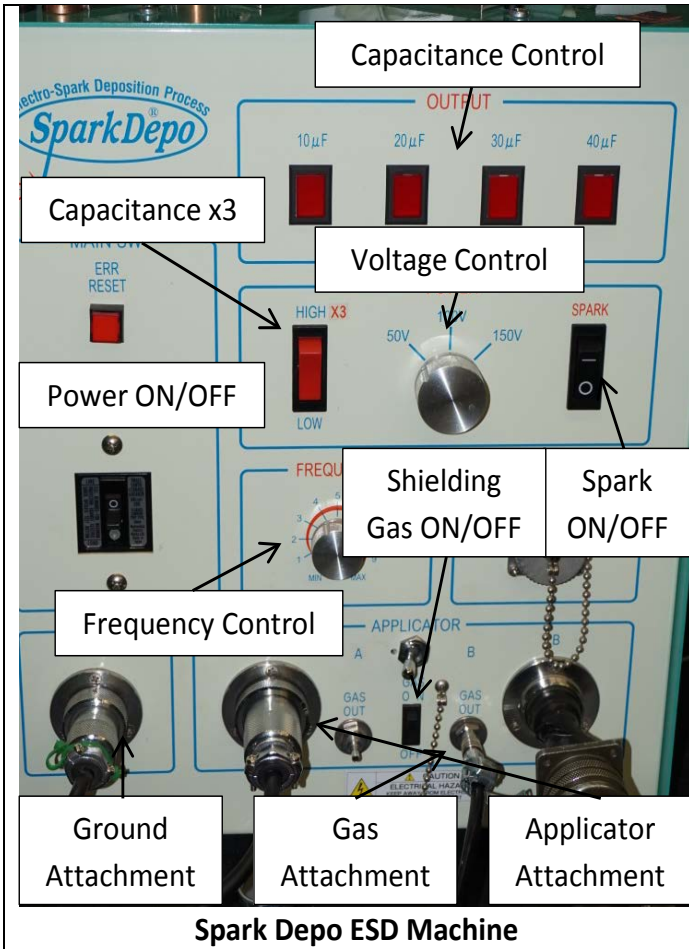

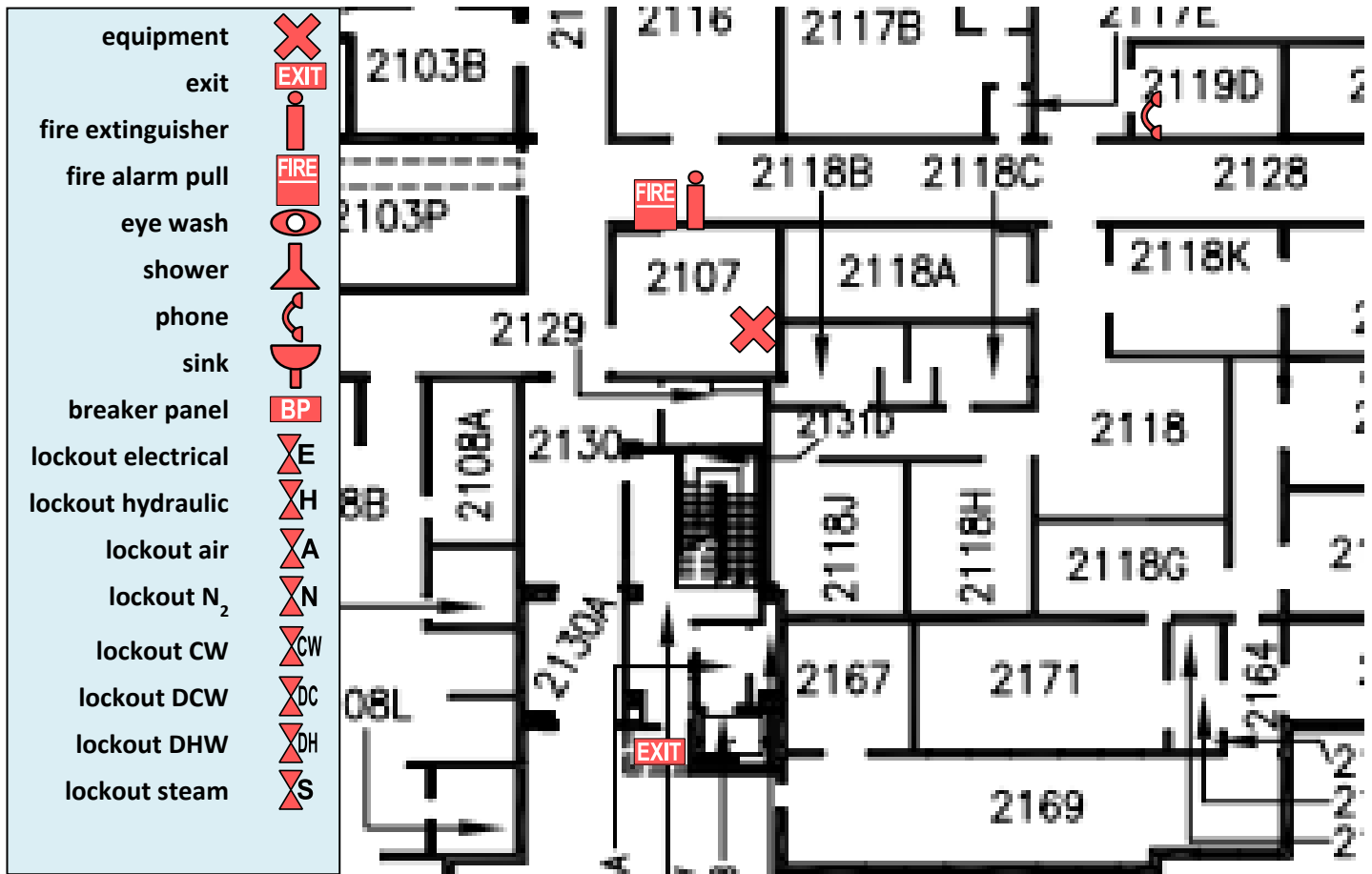

Pre-start Checklist

- Ensure that the lab ventilation fan is on
- Ensure that the door to the lab is closed to protect passers by
- Ensure that the deposition area is clear of flammable media and clutter
- Check the operating condition of the equipment
 - Check the machine power, applicator and grounding cables for fraying and damage
- Don appropriate PPE as listed in the operating procedure
 - Ensure that the operator will not contact the fixtures, ground, substrate or electrode while operating with bare skin
 - Ensure that the machine is securely connected to the wall outlet 15A 120V 60hz
 - Ensure that the Spark Switch is set to OFF before turning on the machine
 - Ensure that the cooling fan is operating when the power is ON
 - Check the shielding gas lines for damage
 - Follow shielding gas operating procedure and the that gas is correctly attached to the SparkDepo machine

Start-up Procedure

- Ensure that the equipment is securely attached to the wall outlet
- Attach the required applicator before turning on the machine
- Attach the ground clamp to the substrate or fixture
- Secure the substrate
- Secure the electrode into the applicator (may require the use of a hex key)
- Turn on the machine (Ensure that the Spark Switch is set to OFF)

- Set the desired capacitance (2.2 μ F to 300 μ F) using the capacitance buttons to add capacitors and the High/Low toggle to multiply the sum of the capacitance by 3 when set to High
- Set the desired Voltage (50-150V) using the Voltage Knob
- Set the desired Frequency using the Frequency Knob (0-10) refer to the SparkDepo manual for the correlation between the SparkDepo settings and the frequency in Hz (see Figure 1)
- Set the A/B toggle to correspond to the desired applicator
- Activate the Shielding Gas Switch if using the Argon Shielding gas
- Follow the appropriate Operating Procedure for the respective applicator

Setting	Frequency (Hz)	Setting	Frequency (Hz)
Min	60	6	700
1	75	7	900
2	120	8	1100
3	150	9	1500
4	260	max	2000
5	360		

Figure 1: Related SparkDepo Frequency Settings converted to Hz

Operating Procedure

- Mini Applicator
 - Choose the desired RPM and direction of the electrode rotation
 - Turn on the rotation
 - Double check that all required PPE is being used
 - Activate the SparkDepo Spark ON/OFF Switch
 - If using shielding gas have partner gauge the gas flow (Applicator, shielding gas and spark switch must be on in order to allow shielding gas flow)
 - Begin deposition
 - If the heat sticker changes colour cease deposition and allow the applicator to cool
 - The mini applicator does not have a internal cooling fan and is thus prone to overheating during extended depositions
- Standard Applicator
 - You may use the wheel on the applicator trigger to meter the rotational speed of the electrode
 - Turn on the SparkDepo spark switch
 - Hold the applicator trigger in order to begin shielding gas flow if desired
 - Have partner gauge the gas flow while holding the trigger
 - Ensure that the electrode is rotating before beginning the deposition
 - Begin Deposition
- Ultrasonic Applicator
 - Plug the US Generator into the back of the SparkDepo Machine
 - Turn on the main power switch on the US Generator (A green light will illuminate)
 - Turn on the operation switch to begin the oscillation
 - Turn on the SparkDepo Spark ON/OFF switch
 - Begin deposition

Shutdown Procedure

- Turn off the Spark ON/OFF switch
- Stop the rotation / oscillation on the respective applicator
- Carefully place the applicator where the electrode will not damage any of the equipment or fixtures (as it remains hot after deposition)

- Switch the High/Low capacitance switch to Low
- Deactivate all of the capacitance switches
- Reduce the voltage knob to 50V
- Turn off the Gas ON/OFF switch
- Power down the SparkDepo machine

Maintenance and Repair

- Refer to the SparkDepo and applicator operating manuals for troubleshooting machine issues
- Contact Dominic Leung for serious problems and electrical issues
- Refer to the ESD Lab Shielding Gas SOP for issues with the shielding gas

Shielding Gas

- When using shielding gas there is a requirement for a minimum of two people to be in the lab
- Ensure that all valves are closed before opening the main cylinder valve
- Avoid extended periods using shielding gas with the lab closed

Startup

1. Ensure that all of the valves are closed before opening the cylinder valve
2. Ensure that the 3/8" MNPT line from the cylinder is correctly attached to the system that you wish to operate
3. Be conscious of the fittings and valves used in the system to which the shielding gas is attached
 - a. Some of the systems have built in switches and valves while others are operated directly from the cylinder needle valve
4. Slowly open the valve on the cylinder,
 - a. The valve only needs to be open a little to provide the required pressure and flow effectively shield the ESD operations
5. Depending on the ESD machine being used the machine may need to be on in order to control the flow at the needle valve attached to the cylinder

SparkDepo Machine

1. The shielding gas will not operate until the 'Gas On' Switch, the 'Spark' switch and the 'Rotation' switch are activated
2. Once ready to deposit initiate all of the circuits
 - a. **WARNING:** Once the switches are on the circuit is active and ready to spark. Do not contact the ground while calibrating the shielding gas flow rate
3. Use the needle valve at the cylinder to calibrate the flow rate
 - a. Down, away from yourself and others in the room

