

Transfer Equipment Resource: Considerations for Promoting Restorative Care and Optimal Client Function

SCOPE

This transfer equipment resource is designed to provide assessors with an organized, diverse range of transfer equipment, to aid in the identification of options which promote independence/rehabilitation for the client. These may minimize the need for 2-person transfers. This document is a thought aid to be used by a regulated mobility professional (e.g., Physiotherapist, Occupational Therapist, Kinesiologist) and used in conjunction with a full assessment that considers factors related to the client (e.g., preferences, restorative goals, cognition, physical abilities, medical conditions), the care provider (e.g., abilities, training) and the environment.

Emphasis is placed on person centred restorative care and balanced, ethical decision making that promotes the needs and choices of the client in the selection of transfers and equipment.

This document addresses equipment which can support clients who have some ability to bear weight and the personal abilities to complete the selected transfer.





NOTES FOR ASSESSORS

- Equipment options are sorted according to the typical level of support that may be provided by the equipment.
- As the *Support for the Client* from the selected equipment increases, the trained care provider may need to contribute lower levels of physical effort.
- Some pieces of equipment have the potential to reduce the client's ability to contribute to their own transfers, thus reducing opportunities for rehabilitation¹.

¹ Smith, J., Simpson, P., Fray, M., (Eds.). (2023) *The Guide to the Handling of People: Person-centred practice 7th Edition*. BackCare.

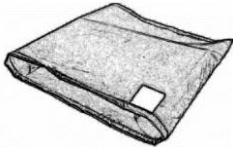



Disclaimer: Clinical judgement and assessment remain the primary guide for a choice of transfers and equipment. This tool offers access to organized information for professional assessors but is not a substitute for clinical training and experience. Specific brands of equipment are not endorsed or promoted; the provided images give a visual understanding of equipment.

Transfer Equipment Resource

EQUIPMENT		CONSIDERATIONS							BODY MOVEMENT / ACTIVITY						
		Movement Pattern: Natural/ Altered	Support for Client from Equipment			Potential for Loss of Rehabilitation Opportunities			Rolling/ Turning in Bed	Lying to Long Sitting	Roll to Sit	Sitting	Sit to Stand	Standing	Walking
			Min	Med	Max	Low	Med	High							
Tubular Slide Sheet		N	X	X		X			X						
Slider Sheet		N	X	X		X			X	X	X				
Bed Lever		N	X			X			X	X	X	X	X		
Bed Hand Blocks		N	X			X			X	X	X				
Mattress Variator/ Elevator		N		X		X			X						

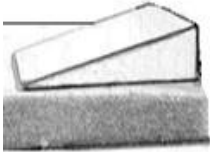

Disclaimer: Clinical judgement and assessment remain the primary guide for a choice of transfers and equipment. This tool offers access to organized information for professional assessors but is not a substitute for clinical training and experience. Specific brands of equipment are not endorsed or promoted; the provided images give a visual understanding of equipment.

Transfer Equipment Resource

EQUIPMENT		CONSIDERATIONS							BODY MOVEMENT / ACTIVITY						
		Movement Pattern: Natural/ Altered	Support for Client from Equipment			Potential for Loss of Rehabilitation Opportunities			Rolling/ Turning in Bed	Lying to Long Sitting	Roll to Sit	Sitting	Sit to Stand	Standing	Walking
			Min	Med	Max	Low	Med	High							
Overbed Pole		A	X			X				X					
Mattress Elevator/ Bed Wedge		N	X				X		X	X	X				
Pillow Wedge		N	X				X		X	X	X				
Bed Ladder		A	X				X		X		X				
Leg Lifter		N	X				X			X					



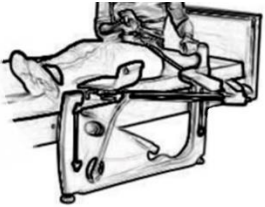
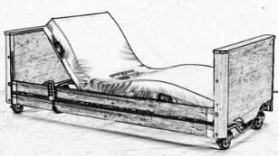
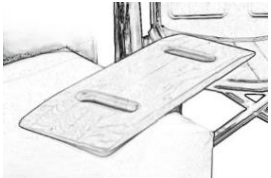

Disclaimer: Clinical judgement and assessment remain the primary guide for a choice of transfers and equipment. This tool offers access to organized information for professional assessors but is not a substitute for clinical training and experience. Specific brands of equipment are not endorsed or promoted; the provided images give a visual understanding of equipment.

Transfer Equipment Resource

EQUIPMENT		CONSIDERATIONS							BODY MOVEMENT / ACTIVITY						
		Movement Pattern: Natural/ Altered	Support for Client from Equipment			Potential for Loss of Rehabilitation Opportunities			Rolling/ Turning in Bed	Lying to Long Sitting	Roll to Sit	Sitting	Sit to Stand	Standing	Walking
			Min	Med	Max	Low	Med	High							
Transfer Pole		A	X				X				X	X	X		
Pillow Lifter/ Powered Back Rest (Electric)		N		X			X		X	X	X				
Leg Lifter (Electric)		N		X			X			X					
Electric Profiling Bed/ Hospital Style Bed		N		X			X	X	X	X	X				
Straight Transfer Board		N	X				X				X				

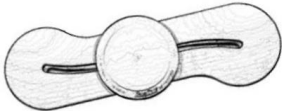

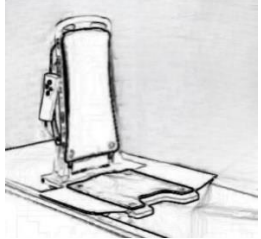

Disclaimer: Clinical judgement and assessment remain the primary guide for a choice of transfers and equipment. This tool offers access to organized information for professional assessors but is not a substitute for clinical training and experience. Specific brands of equipment are not endorsed or promoted; the provided images give a visual understanding of equipment.

Transfer Equipment Resource

EQUIPMENT		CONSIDERATIONS							BODY MOVEMENT / ACTIVITY						
		Movement Pattern: Natural/ Altered	Support for Client from Equipment			Potential for Loss of Rehabilitation Opportunities			Rolling/ Turning in Bed	Lying to Long Sitting	Roll to Sit	Sitting	Sit to Stand	Standing	Walking
			Min	Med	Max	Low	Med	High							
Curved Transfer Board		N	X				X				X				
Beasy Board		N	X				X				X				
Furniture Blocks or Height-Adjustable Chair		N	X				X				X	X			
Bath Lift		A		X			X						X	X	
Bench		N	X				X				X	X			

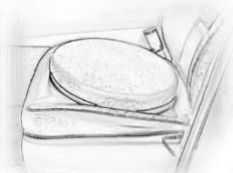
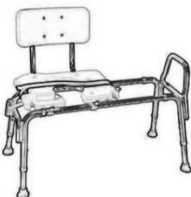

Disclaimer: Clinical judgement and assessment remain the primary guide for a choice of transfers and equipment. This tool offers access to organized information for professional assessors but is not a substitute for clinical training and experience. Specific brands of equipment are not endorsed or promoted; the provided images give a visual understanding of equipment.

Transfer Equipment Resource

EQUIPMENT		CONSIDERATIONS							BODY MOVEMENT / ACTIVITY						
		Movement Pattern: Natural/ Altered	Support for Client from Equipment			Potential for Loss of Rehabilitation Opportunities			Rolling/ Turning in Bed	Lying to Long Sitting	Roll to Sit	Sitting	Sit to Stand	Standing	Walking
			Min	Med	Max	Low	Med	High							
Car Cushion Swivel Seat		N	X				X					X			
Sliding Transfer Bench/ Shower Chair		N		X			X					X	X		
Raised Toilet Seat		N	X				X					X			
Toilet Surround		N	X				X					X			
Grab Bar/ Railing		N	X				X					X	X	X	

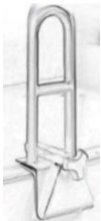
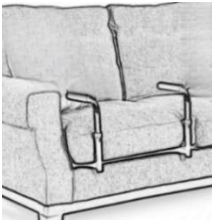

Disclaimer: Clinical judgement and assessment remain the primary guide for a choice of transfers and equipment. This tool offers access to organized information for professional assessors but is not a substitute for clinical training and experience. Specific brands of equipment are not endorsed or promoted; the provided images give a visual understanding of equipment.

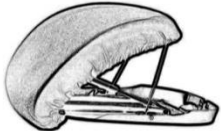
Transfer Equipment Resource

EQUIPMENT		CONSIDERATIONS							BODY MOVEMENT / ACTIVITY						
		Movement Pattern: Natural/ Altered	Support for Client from Equipment			Potential for Loss of Rehabilitation Opportunities			Rolling/ Turning in Bed	Lying to Long Sitting	Roll to Sit	Sitting	Sit to Stand	Standing	Walking
			Min	Med	Max	Low	Med	High							
Tub Clamp-on Rail		N	X				X					X	X	X	
Chair Arm/ Riser Arm		N	X				X					X			
Car Support Handle		N	X				X					X			
Car Sling		A	X				X					X			
Riser Cushion/ Seat Assist Riser (Electric)		N		X			X					X			



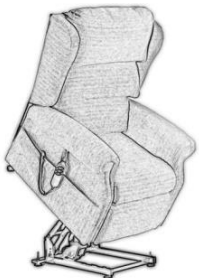

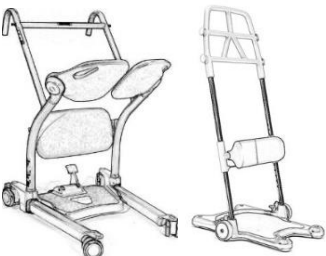
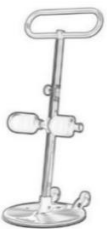
Disclaimer: Clinical judgement and assessment remain the primary guide for a choice of transfers and equipment. This tool offers access to organized information for professional assessors but is not a substitute for clinical training and experience. Specific brands of equipment are not endorsed or promoted; the provided images give a visual understanding of equipment.

Transfer Equipment Resource

EQUIPMENT		CONSIDERATIONS							BODY MOVEMENT / ACTIVITY						
		Movement Pattern: Natural/ Altered	Support for Client from Equipment			Potential for Loss of Rehabilitation Opportunities			Rolling/ Turning in Bed	Lying to Long Sitting	Roll to Sit	Sitting	Sit to Stand	Standing	Walking
			Min	Med	Max	Low	Med	High							
Riser Chair (Electric)		N		X				X				X			
Standing Aid Cane		N		X				X				X	X		
Sit-to-Stand Device (Non-motorized)		A		X				X				X			
Sit-to-Stand Patient Transfer Turning Aid		A		X				X				X			



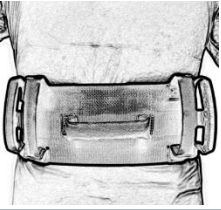

Disclaimer: Clinical judgement and assessment remain the primary guide for a choice of transfers and equipment. This tool offers access to organized information for professional assessors but is not a substitute for clinical training and experience. Specific brands of equipment are not endorsed or promoted; the provided images give a visual understanding of equipment.

Transfer Equipment Resource

EQUIPMENT		CONSIDERATIONS							BODY MOVEMENT / ACTIVITY						
		Movement Pattern: Natural/ Altered	Support for Client from Equipment			Potential for Loss of Rehabilitation Opportunities			Rolling/ Turning in Bed	Lying to Long Sitting	Roll to Sit	Sitting	Sit to Stand	Standing	Walking
			Min	Med	Max	Low	Med	High							
Sit-to-Stand Device (Motorized)		N or A		X				X				X			
Framed Turn Disc/Pivot Disc		A	X					X				X			
Transfer/Gait Belt		N	X					X				X	X	X	
Walking Stick/Cane		N	X					X					X	X	
Quad Cane		N	X					X				X	X	X	

Disclaimer: Clinical judgement and assessment remain the primary guide for a choice of transfers and equipment. This tool offers access to organized information for professional assessors but is not a substitute for clinical training and experience. Specific brands of equipment are not endorsed or promoted; the provided images give a visual understanding of equipment.

Transfer Equipment Resource

EQUIPMENT		CONSIDERATIONS							BODY MOVEMENT / ACTIVITY						
		Movement Pattern: Natural/ Altered	Support for Client from Equipment			Potential for Loss of Rehabilitation Opportunities			Rolling/ Turning in Bed	Lying to Long Sitting	Roll to Sit	Sitting	Sit to Stand	Standing	Walking
			Min	Med	Max	Low	Med	High							
Elbow Crutches		N	X				X					X	X	X	
Walking Frame/Walker		N	X				X						X	X	
Wheeled Walker/Rollator		N	X				X						X	X	
Ambulation Sling used with Mechanical Lift		N	↔				X							X	

Disclaimer: Clinical judgement and assessment remain the primary guide for a choice of transfers and equipment. This tool offers access to organized information for professional assessors but is not a substitute for clinical training and experience. Specific brands of equipment are not endorsed or promoted; the provided images give a visual understanding of equipment.