

NEWBIT

A NEWSLETTER FROM THE INSTITUTE FOR QUANTUM COMPUTING, UNIVERSITY OF WATERLOO

on the trapped ion trail

04 NOBEL PRIZE IN PHYSICS 09 SCIENCE HIGHLIGHTS 17 IQC OUTREACH



UNIVERSITY OF
WATERLOO

IQC

Institute for
Quantum
Computing



UNIVERSITY OF
WATERLOO



Institute for
Quantum
Computing

this issue

INSPIRING FUTURE QUANTUM LEADERS pg 05

High school students learn about quantum cryptography at QCSYS.

ON THE TRAPPED ION TRAIL pg 07

IQC researcher **CRYSTAL SENKO** and her team are paving the way towards a trapped-ion quantum computer.

A SCIENTIST WITH A NOSE FOR BUSINESS pg 19

PhD student **ANDREW CAMERON** experiments in the startup world.

ON THE COVER

CRYSTAL SENKO in the Trapped Ion Quantum Control lab.

Cover photo by: IQC

SPRING/FALL 2018

publisher

**IQC COMMUNICATIONS &
STRATEGIC INITIATIVES**

UWATERLOO.CA/IQC

Institute for Quantum Computing
200 University Avenue West
Waterloo, Ontario, Canada N2L 3G1

Phone: 1 - 519 - 888 - 4021
Fax: 1 - 519 - 888 - 7610
Email: iqc@uwaterloo.ca

FROM THE EDITOR

It was an exciting time in the world of science and at the University of Waterloo when the recipients of the Nobel Prize were announced on October 2. Professor in the Department of Physics and Astronomy **DONNA STRICKLAND** was awarded the 2018 Nobel Prize in Physics for her research in the field of laser physics (page 4). In 1985, Strickland developed chirped pulse amplification with **GÉRARD MOUROU**, her PhD supervisor at the time. Since then, her research has led to applications across industry and medicine.

As Strickland's journey to the Nobel Prize demonstrates, the leap from fundamental research to technological applications isn't always immediate. At the Institute for Quantum Computing (IQC), researchers are advancing quantum information science and technology research every day.

In this issue, you will set forth on the trapped ion trail with **CRYSTAL SENKO** to learn about the steps she's taking to enable large-scale quantum computing with trapped ions (page 7). Using a different approach to trapped-ion quantum computing, she envisions creating qudits instead of qubits where three, five or even more states are available in each ion.

You will also read about exciting research results including the demonstration of a quantum advantage with shallow circuits, an advancement by faculty member **DAVID GOSSET** and collaborators that *Science Daily* calls the establishment of "a cornerstone in this promising field [of quantum computing]" (page 9).

Over the last few months, IQC students, faculty and staff continued to share quantum information science and technology at conferences, workshops and outreach events across the globe (page 17), inspiring others to join the quantum journey.

KATHRYN FEDY

*Senior Manager, Integrated Marketing
Institute for Quantum Computing*

NEWBIT | ISSUE 35 | SPRING/FALL 2018

IN

CANADA | NEWBIT | ISS
2018 | INSTITUTE FOR Q
ONTARIO, CANADA | IN
RING/FALL 2018 | INSTITUTE FOR QUANTUM COMPUTING, UNIVERSITY OF WATERLOO, ONTARIO, CANADA | NEWBIT | ISSUE 35 | UNIVE
R QUANTUM COMPUTING | NEWBIT | ISSUE 35 | 2018 | INSTITUTE FOR QUANTUM



NEW FACULTY MEMBER

Theorist **DAVID GOSSET** returned to the Institute for Quantum Computing (IQC) as associate professor in the Department of Combinatorics and Optimization in August 2018.

After pursuing postdoctoral fellowships at IQC and the California Institute of Technology (Caltech), Gosset worked with the IBM T.J. Watson Research Center, managing the Theory of Quantum Algorithms group. His research broadly includes the investigation of fundamental questions in quantum algorithms and quantum complexity theory.

At IQC, Gosset continues to guide the way toward promising use cases for the next generation of quantum computers.

He is investigating novel ways that quantum computers can achieve an advantage over classical computers, the limits of classical simulation methods, and the computational complexity of quantum many-body systems. ■



Waterloo professor awarded

2018 Nobel Prize in Physics

The Institute for Quantum Computing (IQC) congratulates **DONNA STRICKLAND**, professor in the Department of Physics and Astronomy, on receiving the 2018 Nobel Prize for her research in the field of laser physics.

"I am beyond thrilled to congratulate my colleague Donna Strickland," said **RAYMOND LAFLAMME**, past director of IQC. "Her ground-breaking work has propelled research in this field forward, leading to discoveries and applications in laser physics and enabling experiments in other areas, including quantum information."

Strickland conducted her Nobel-winning research while a PhD student with French laser physicist **GÉRARD MOUROU**, with whom she shares the prize. Their work paved the way toward the shortest and most intense laser pulses ever created by humankind. The team's research has a number of applications in industry and medicine, including the millions of corrective eye surgeries that are conducted every year using the sharpest of laser beams.

"It's an exciting time for physics at the University of Waterloo," said interim executive director **KEVIN RESCH**. "We extend heartfelt congratulations to Donna for her extraordinary contribution to science." ■



QCSYS

Quantum Cryptography
School for Young Students

Inspiring future quantum leaders

For eight days every August, IQC brings together 40 high school students from around the world for the Quantum Cryptography School for Young Students (QCSYS). This intense enrichment program is designed to explore the physics and mathematics of quantum mechanics and cryptography, and inspire participants to lead quantum technologies into the future.

For young people with an interest in physics and science, QCSYS provides a unique opportunity to develop and channel their knowledge. For IQC's Manager, Scientific Outreach and QCSYS leader **JOHN DONOHUE**, it's about capturing students' imaginations when they're young. "An interest in physics can grow in students before they even get to high school," Donohue observed. But with a complex topic like quantum, which can be difficult to self-teach and is only touched upon in the high-school curriculum, it can be hard to develop that interest. What QCSYS does, said Donohue, is provide "a direction and outlet for a student's curiosity" with the additional benefit of introducing them to like-minded peers.

Since its inception in 2008, QCSYS has engaged over 440 alumni. It's a competitive program that receives six times as many applications as there are places, and it's open to students aged 15 and older who have a genuine interest in math and science.

The school is a mix of taught sessions, delivered by Donohue and a team of IQC graduate students; talks by IQC faculty members and visitors; and hands-on lab-based activities and experiments. An afternoon at the Perimeter Institute in Waterloo complements the intense study. But it's not all hard work. The program includes an essential day trip to Niagara Falls as well as activities such as bowling and Laser Quest in the evening. Staying in University of Waterloo residences gives the students a further glimpse into undergraduate life.

By bringing these talented young people together each year for, in the words of one participant, "a once in a lifetime experience", IQC is nurturing the next generation of quantum leaders. ■

FEATURE ARTICLE

A photograph of three scientists in a laboratory setting. On the left, a man with dark hair and a beard, wearing a grey and white striped t-shirt, looks towards the center. In the middle, a man with blonde hair and glasses, wearing a dark red turtleneck sweater, looks down at a red ring-shaped object. On the right, a woman with dark hair tied back, wearing a blue denim shirt, holds the red ring-shaped object with both hands and examines it closely. The background shows laboratory equipment and a bright light source, possibly a window. The overall atmosphere is one of focused scientific inquiry.

on the trapped
ion trail

As a physics undergraduate student, Crystal Senko explored the labs of Duke University, not realizing she was about to set forth on a future career path in quantum research. Intrigued by a forest of optics on the table of an atomic physics lab, she entered the world of experimental research and hasn't looked back.

Now, as principal investigator of the Trapped Ion Quantum Control lab at the Institute for Quantum Computing (IQC), Senko and her team are paving the way towards the realization of a trapped-ion quantum computer.

PROMISING HARDWARE

Trapped ions offer a promising path to viable, hardware-based quantum computing. Senko, also an assistant professor in the Department of Physics and Astronomy in the Faculty of Science, pushes the boundaries of what is possible with this technology.

To realize the information processing advantages of quantum computing, the first step is to focus on the capabilities of the physical hardware used to implement the processing. Current hardware has limitations due to temperature, qubit control, and/or error correction. Senko has placed her bets on trapped ions as a technology that will overcome these obstacles and enable large-scale quantum computing.

Trapped ions are electrically charged atoms suspended inside a vacuum chamber with electrodes. The chamber provides extreme isolation to protect the ions from troublesome noise and interference. Once ions are trapped, researchers can encode bits of information in the spin of their outer electrons. Ion trapping is considered one of the most advanced areas within the field of quantum computing. With the proper setup, researchers can already control about 20-30 qubits at once.

Faculty member **CRYSTAL SENKO** discusses a three-dimensional model for ion trapping with Master's student **BRENDAN BRAMMAN** and postdoctoral fellow **MATTHEW DAY**.

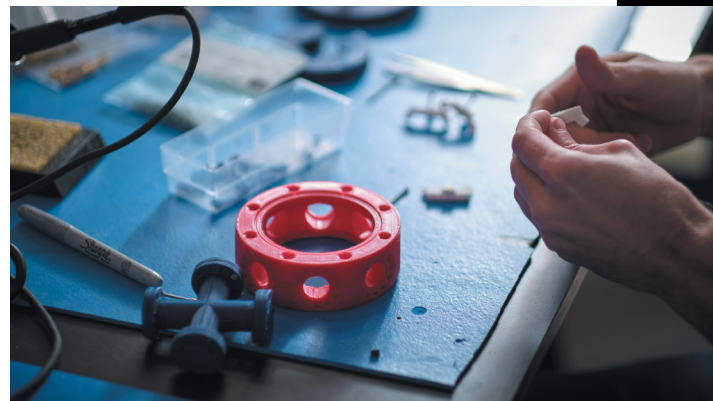

Senko works on the three-dimensional model of the chamber that will be used to trap the ions in the lab.

FROM QUBITS TO QUDITS

Right now, the more qubits researchers try to connect at once, the less control there is. More qubits and more precise control are necessary for the kind of large-scale quantum computing that could lead to further advances in information security, simulations of complex systems, and other applications with the potential to shake up current science and technology. Senko plans a different approach to trapped-ion quantum computing; instead of encoding just zeroes or ones in each ion to create qubits, she envisions three, five or even more states encoded in each ion, making them qudits.



Optics table set-up in the Trapped Ion Quantum Control Lab.

There is one idea in particular that Senko has been incubating with other researchers at IQC. Senko envisions a small quantum computer based on trapped ions available for use to other researchers, at first.

“We hope this machine will strengthen the bonds between theorists and experimentalists—turn theorists from people who think about how to use quantum computers into people who use a quantum computer,” said Senko. “Feedback from them could be used to speed up the development cycle.”

Eventually, Senko hopes this quantum computer would be available to the international research community as a cloud-computing platform. For now, however, this in-house quantum computer remains an idea.

What’s exciting for Senko is how a simple idea can lead to so much more than anyone could predict in science. She uses the example of the atomic clock to illustrate: American physicist and winner of the 1989 Nobel Prize in Physics Norman Ramsey wanted to accurately study the structure of atoms and molecules. He developed a technique called the separated oscillatory fields method, now known as the Ramsey method. Little did he know, his work would be crucial for the development of atomic clocks and spawn the development of the entire Global Positioning System (GPS) on which we rely for navigation today.

The work done by Senko’s group now may very well be blazing the trail to a goal that researchers around the globe are striving for: large-scale quantum computing. ■

“No one has really done this in the lab yet,” said Senko, “so we’re taking the first baby steps.” Baby steps might not sound exciting, but they are one sign a researcher is at the absolute cutting edge of a field.

WHAT LIES AHEAD

In the relatively short-term, it seems likely to Senko that trapped-ion systems will be useful for studying medium-scale spin systems. These simulations will allow researchers to study quantum chemistry, high energy physics and other fundamental areas with unprecedented detail and accuracy. What really excites Senko are the even greater long-term possibilities.

“I think that the technology has the generality and potential that people are going to find applications that haven’t even been thought of yet,” said Senko.

SCIENCE HIGHLIGHTS

IQC faculty, postdoctoral fellows and students continue to conduct internationally recognized quantum information science research. Here is a sampling of their research published in academic journals.

Showing a quantum advantage with shallow circuits

Science 362, 308-311

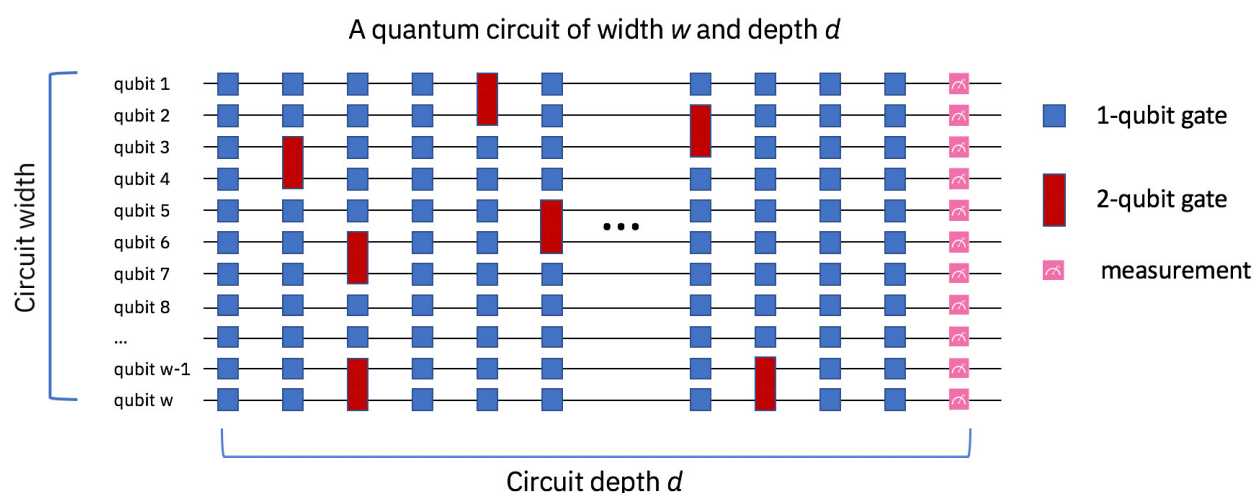

Scientists prove there are certain problems that require only a fixed circuit depth when done on a quantum computer no matter how the number of inputs increase. On a classical computer, these same problems require the circuit depth to grow larger.

Quantum computers can solve a linear algebra problem faster than classical computers, according to a study published in *Science*. The finding proves that constant-depth quantum circuits are more powerful than their classical counterparts, and provides a new sense of how quantum technology will be a key to more powerful computing.

The study, conducted by a team of researchers at IBM T.J. Watson Research Center including **SERGEY BRAVYI**, IQC faculty member **DAVID GOSSET**, and **ROBERT KÖNIG** of the Technical University of Munich (TUM), could also guide the way toward promising use cases for the next generation of quantum computers.

The team of researchers considered constant-depth circuits, meaning that the depth or number of time steps is independent of the number of qubits. They discovered that a quantum computation with a constant number of time

steps – a constant-depth quantum circuit – could solve a certain linear algebra problem called the 2D Hidden Linear Function problem. Furthermore, they demonstrated that no classical computation of constant depth could solve the same problem, uncovering a new quantum advantage over classical computers.

The results open up new possibilities for quantum algorithm development and raise the question of whether such a speed-up can persist in the presence of noise processes that occur in currently available technology. According to *Science Daily*, Gosset and collaborators have established “a cornerstone in this promising field [of quantum computing].”

[WEB bit.ly/quantum-advantage](https://bit.ly/quantum-advantage)

[WEB bit.ly/science-daily-qc-advantage](https://bit.ly/science-daily-qc-advantage) ■

Generating multiphoton entanglement on a superconducting chip

Phys. Rev. Applied 10, 044019

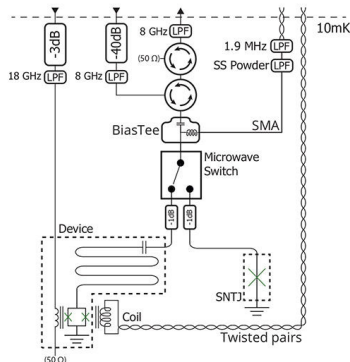

7 A simplified schematic of the measurement setup.

A team of researchers at the Institute for Quantum Computing (IQC) generated three-photon entanglement on a superconducting chip using a new, scalable technique. The experiment, led by IQC researcher CHRISTOPHER WILSON, could lead to advances in quantum communication protocols like secret sharing and in quantum computing power.

To generate multiphoton entanglement, Wilson and his team created quantum states of microwave light at frequencies near 5 GHz-- the same frequency band as wireless communications used by cellphones and Wi-Fi connections. The team designed a special superconducting circuit that acts as a microwave cavity.

The photons are entangled on the chip through a process known as parametric down conversion, where high-frequency magnetic fields are applied to a superconducting quantum interference device (SQUID) integrated into the cavity. This changes the system's electrical properties and, as a result, also the frequency of the photons in the microwave cavity. When the frequency-changing signal is pumped into the circuit, the photons are split to create sets of photons that are entangled with each other. Changing the frequency also moves the photons between modes, or sections, of the circuit.

"If we apply a magnetic field at the sum of two cavity frequencies, the photons that are created each go into one of two modes, producing two photons of different frequencies, or different colours, but they are still entangled." Wilson uses the analogy of a dancer dressed in red and another dressed in blue, but they are still moving in synchrony.

The researchers demonstrated three-photon entanglement, however the new method is extendable for adding more entangled quantum states. The results could yield promising engineering advances for building a superconducting quantum computing platform.

Generating Multimode Entangled Microwaves with a Superconducting Parametric Cavity was published in *Physical Review Applied*. This research was undertaken thanks in part to funding from the Canada First Research Excellence Fund.

WEB bit.ly/multiphoton-entanglement-sc-chip ■

New methods to produce and detect optical and matter-wave spin-orbit states

Phys. Rev. Lett. 121, 183602

New J. Phys. 20, 103012

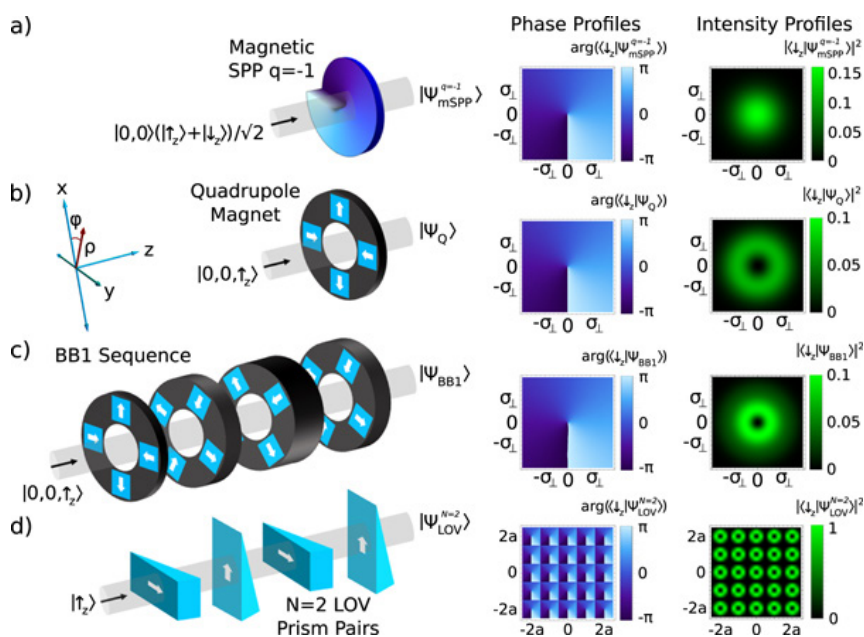

In the first study, the researchers created a beam of light consisting of a lattice of spin-coupled OAM states. It is the first time that this technique has been applied to optics. To produce the spin-coupled OAM states of light, the researchers used coherent averaging and spatial control methods adapted from nuclear magnetic resonance.

A new characterization method for neutrons was also introduced. The method can directly measure the correlations between the spin and transverse momentum states, overcoming the major challenges associated with neutrons – low flux and small spatial coherence length.

Researchers at IQC, in collaboration with researchers at the National Institute for Standards and Technology (NIST), have developed a robust method for structuring light and matter waves, enhancing the powerful probing ability of neutrons.

“The hope is that this detection procedure can be extended to other probes such as electrons and X-Rays,” said **DUSAN SARENAC**, Technical Lead, Quantum Early Adopters for Transformative Quantum Technologies (TQT).

This research was undertaken thanks in part to funding from the Canada First Research Excellence Fund.

WEB bit.ly/gen-lattice-spin-orbit

WEB bit.ly/neutron-spin-orbit-states ■

Controlling a property of light called Orbital Angular Momentum (OAM) has led to applications in communication, microscopy and manipulating quantum information. Recently, in two different studies, IQC researchers demonstrated a new method of structuring spin-coupled OAM and offers new approaches to the study of magnetic and chiral materials.

CONFERENCES & WORKSHOPS



IQC researcher **RAYMOND LAFLAMME** speaks with students at the Quantum Cryptography School for Young Students (QCSYS) mentoring session.

Inspiring future scientists

In August, IQC hosted 40 secondary school students for the Quantum Cryptography School for Young Students (QCSYS), an intense enrichment program that introduces young people to the field of quantum cryptography. For eight days, these curious students enjoyed a blend of theory and applications through lectures and hands-on experiments. When they weren't working in the lab or speaking with mentors from IQC, students caught a glimpse of the university experience, living in residence and going on trips with classmates from around the globe. ■

Workshop on Security Proofs in QKD

On July 5 and 6, IQC hosted a two-day workshop on Security Proofs in Quantum Key Distribution (QKD). The aim was to give researchers working in this field the opportunity to discuss and compare different approaches, explore how to reduce assumptions, and attempt to define a coherent view on security proofs, claims and assumptions in practical QKD. ■

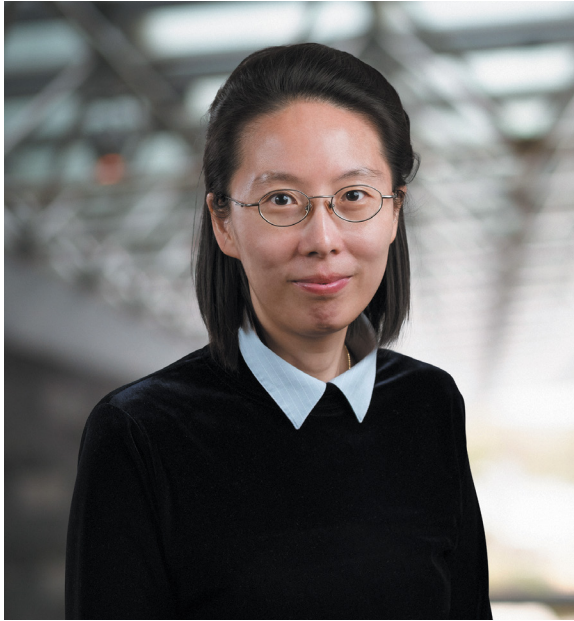

7 NA YOUNG KIM

Sharing quantum with industry

Faculty member **NA YOUNG KIM** delivered a presentation about IQC and its research initiatives at the Quantum Computing Summit in San Francisco on September 19. This major event is a division of the AI (Artificial Intelligence) Summit, the world's largest AI event for business, which welcomes over 4000 delegates for two days of conference sessions, networking meetings and exhibitions. ■

IQC-China Conference on Quantum Technologies

Scientists from China and Canada came together at the IQC-China Conference on Quantum Technologies at the beginning of October. For six days, participants shared research and explored opportunities for collaboration through a full program of presentations and networking sessions.

IQC faculty, Canada Excellence Research Chair Laureate and conference organizing committee member **DAVID CORY**, and Vice-President of Tsinghua University **QI-KUN XUE**, gave the opening keynote addresses on impactful small quantum devices and physics beyond Ohm's Law respectively. ■

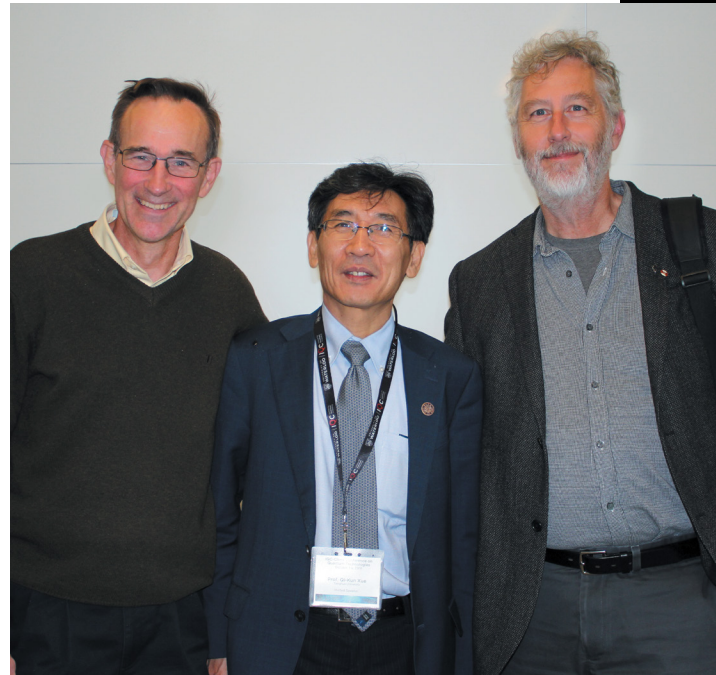

7 IQC researchers **RAYMOND LAFHAMME** (left) and **DAVID CORY**, Canada Excellence Research Chair Laureate (right) stand with **QI-KUN XUE** (center) of Tsinghua University.

CONFERENCES & WORKSHOPS



Quantum Opportunities

On October 3, scientists, entrepreneurs and investors from the global quantum ecosystem came together in Vancouver for Quantum Opportunities 2018. The conference, organized by Transformative Quantum Technologies (TQT) and Vanedge Capital, sparked conversation about opportunities within quantum computing and broader quantum technologies, as well as the prospects and timeline for commercialization and real-world applications. IQC faculty

member and Canada Excellence Research Chair Laureate **DAVID CORY** and IQC faculty member **JOSEPH EMERSON** were among the keynote speakers.

TQT is a collaborative research initiative connected to IQC that aims to accelerate the development of impactful quantum devices, and is funded in part by the Canada First Research Excellence Fund (CFREF). ■

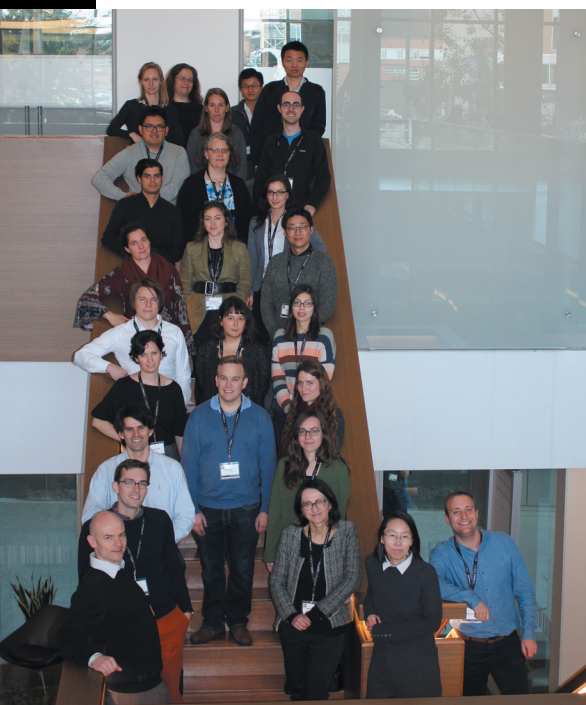

Quantum Innovators

For the second year running, IQC organized and hosted two workshops designed to bring together promising postdoctoral fellows and early career researchers. Quantum Innovators in Science and Engineering, October 15-18, hosted 28 experimentalists and theorists studying quantum physics and engineering. Quantum Innovators in Computer Science and Mathematics, October 22-26, gathered 22 computer scientists and mathematicians working on theoretical aspects of computation and quantum information.

Participants in both groups explored the frontier of quantum information science and technology by sharing their own research and learning about the work of their peers. Both workshops were partly funded by the Canada First Research Excellence Fund (CFREF) as part of the Transformative Quantum Technologies (TQT) research initiative. ■



Creating a quantum-safe cryptographic infrastructure

Industry, academic and government collaborators came together in Beijing to explore next steps in creating a quantum-safe cryptographic infrastructure at the 6th Quantum Safe Cryptography Workshop, organized through a partnership between IQC, the European Telecommunications Standard Institute (ETSI) and Chongqing University.

At the three day meeting in November, the most recent requirements of cryptographic infrastructure by industry and government were presented, followed by proposed solutions offered by the latest research in the field. ■



Waterloo at CSCP

Waterloo's innovation agenda was the topic of an IQC/University of Waterloo sponsored breakfast at the Canadian Science Policy Conference in Ottawa. The University of Waterloo's Dean of Science **ROBERT LEMIEUX** chaired the discussion, which focused on Waterloo Region as the ideal place to start a business. IQC PhD student **KRISTINE BOONE** was among the panel members and well placed to comment on the Waterloo innovation advantage. Her research, under the supervision of **JOSEPH EMERSON**, contributed to the creation of Quantum Benchmark, a Kitchener-Waterloo based startup that develops software tools to assess and improve the performance of quantum computers. Boone commented,

“Waterloo is a very different environment to grow a company in. Any help you would need to do anything, there is someone in town that can help you.” ■

PRESENTATIONS

Canada's Quantum Valley leads by example

Canada's Quantum Valley: An Integrated Pathway to the High-Tech Future was the focus of a one-day public event held in October by the Hudson Institute's Quantum Alliance Initiative in Washington, DC. Leading experts from business, government and academia gathered to learn about the unique processes and best practices of the evolving quantum ecosystem in Waterloo Region, Canada's Quantum Valley.

Chair of the board and visionary **MIKE LAZARIDIS** delivered a keynote address outlining the systematic approach in the creation of Quantum Valley and described why integration is the key to how it works. **ARTHUR HERMAN**, director of Hudson's Quantum Alliance Initiative, moderated a panel discussion with Lazaridis and IQC past director **RAYMOND LAFLAMME**, exploring the potential impact of quantum technologies and IQC's leading role as the Quantum Valley hub. IQC researcher and founder of startup Quantum Benchmark, **JOSEPH EMERSON**, presented an overview of the reality of quantum computing. ■



VISITS & TOURS

Industry, government and academic partners from all over the world visit IQC to learn about the research happening here, tour the facilities, and discuss opportunities for collaboration. In the second half of the year, IQC was honoured to host more than **284 visitors from 29 delegations** including:

- » The President and Pro Vice Chancellor, University of Adelaide
- » Alibaba Quantum Computing Laboratory
- » 1QBit
- » SSIMWAVE Inc./Comcast Corporation
- » IBM ■

IQC OUTREACH

IQC brings the world of quantum information science and technology to the curious-minded through unique outreach opportunities designed to share the fascinating research that is changing the way we live, work and play.

In July, IQC welcomed groups for tours, workshops or lectures, including:

- EinsteinPlus, Perimeter Institute
- IDEAS Summer Experience
- International Students School for Young Physicists, Perimeter Institute
- Exploring Science Program
- Physics Days ■



QUANTUM: The Pop-Up Exhibition lands in Regina

In October, **QUANTUM: The Pop-Up Exhibition** engaged more than 14,500 visitors at its latest stop, the Saskatchewan Science Centre in Regina. Designed after **QUANTUM: The Exhibition**, the Pop-Up is a modular, 300 square foot, portable exhibit that has travelled across Canada, and to the United States and Europe, engaging over 37,000 visitors with the concepts of quantum information science and technology. ■



**SASKATCHEWAN
SCIENCE CENTRE**

A Nobel perspective on ultracold science

Why do physicists freeze matter to extremely low temperatures? Why is it worthwhile to cool to temperatures which are a billion times lower than that of interstellar space? **WOLFGANG KETTERLE**, 2001 Nobel Laureate and Massachusetts Institute of Technology (MIT) professor, explored these questions and more on September 27 at the Quantum Frontiers Distinguished Lecture. Ketterle described his Nobel award-winning work with ultracold matter, including superfluids that can flow without dissipation. ■





Entangled: The series connects again

Quantum is the new rocket science

Delving into popular portrayals of quantum in movies and television shows, scientific outreach manager **JOHN DONOHUE** led *QUANTUM + Pop culture* on November 15.

Rife with humour and poking fun at many of the less-than-scientifically accurate depictions of quantum physics in media, Donohue went a long way into untangling science fact from science fiction. He established how quantum physics is so often delivered as a punchline, shorthanded into something complex or used as a buzzword. Through fun analogies, videos and demonstrations, Donohue provided the scientifically accurate explanation of the principles of quantum mechanics and engaged the audience with familiar scenes from favourite films. ■

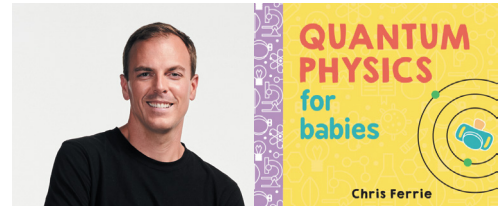

QUANTUM + opportunity: Big ideas for little minds

Chris Ferrie, IQC alumnus and now children's author, invited the audience to think about the pivotal role we each have in inspiring our future scientific leaders at the fourth presentation of *Entangled: The series*, exploring quantum and opportunity.

Sharing his experiences and his journey of coming of age with digital software, Ferrie emphasized the importance of supporting the development of today's youth as tomorrow's leaders in quantum technology. Ferrie believes children will take advantage of the opportunities they are given, but only if their parents and teachers show genuine interest in the activities giving rise to those opportunities. The child that will come of age with the next quantum revolution needs to have the seeds of curiosity sown today. He encouraged the audience to provide that kind of support, allowing little minds to grow the big ideas of the future. ■

Schrödinger's Class in session

Visiting teachers from across Canada became students of quantum information and science technology for Schrödinger's Class, a workshop for science educators. Over three days, 40 participants attended lectures and participated in hands-on activities to learn about integrating quantum technology into the teaching curriculum. Invigorated by their experience, teachers left the workshop ready to discuss cutting-edge advances in the field and prepared with ready-made lesson plans to present to their students. ■



Quantum + Beer

From communication to privacy, healthcare to the environment, quantum technologies are poised to impact many areas of society. **MARTIN LAFOREST**, IQC's scientific outreach advisor and quantum technology expert at ISARA Corporation, used different types of beer as a starting point to explain the power of quantum mechanics and the emerging applications of quantum technologies at *Quantum + Beer* in November. The event, co-hosted by IQC and the Royal Canadian Institute of Science (RCIS), brought quantum to the community at Patent Social in Waterloo. ■

Around the INSTITUTE

A scientist with a nose for a business



PhD student PROFILE: **ANDREW CAMERON**

PhD student **ANDREW CAMERON** claims to be not very good at making career decisions. “I just follow what I like,” he said, reflecting on his journey to IQC. Excelling in math, a high school demonstration of how theory could translate to physical experiment and then to tangible results drew Cameron towards the study of physics. Then, moving on to the University of Prince Edward Island, he took a class in quantum chemistry and read an article about the future of quantum computing that inspired him to follow a path towards quantum information research.

“I didn’t know anything about quantum computing,” he admitted, “but I knew if there was a chance that it was the future, then I definitely wanted to be a part of that.”

Cameron kept an open mind when applying for graduate school, knowing only that he wanted to be involved in quantum information in some way. After considering various options, he decided on the University of Waterloo’s Department of Physics and Astronomy and IQC because he was interested in what his chosen research group did in the Quantum Optics and Quantum Information lab.



These instinctual choices have paid off. He joined IQC in 2017 to start graduate research in quantum optics, and, in September 2018, Cameron received what he described as “world-altering” news. He had been awarded a prestigious Vanier Canada Graduate Scholarship.

EXPLORING PHOTON FREEDOM

Cameron’s PhD project is a collaboration between groups led by his supervisor and interim executive director **KEVIN RESCH** with faculty members **DMITRY PUSHIN**, Canada Research Excellence Chair Laureate **DAVID CORY** and **THOMAS JENNEWEIN**. His research looks at how information carried by individual particles of light can be harnessed using the quantum phenomena of entanglement and teleportation. Specifically, he’s exploring methods of manipulating electromagnetic beams consisting of a lattice of spin-coupled orbital angular momentum (OAM) states. This research could lead to significant improvements in information security and computing power.

“OAM states are of particular interest because they provide a different degree of freedom for photons involving their spatial properties,” said Cameron.

“Exploring this degree of freedom allows for high dimensional encoding of information.”

High dimensional entanglement is required for many quantum computing and quantum information protocols, including the possibility for establishing highly secure communication channels over long distances.

“Before quantum communication can be effective, it needs to be secure and robust over long distances,” Cameron observed. “Quantum optics is one avenue of making this happen.”

TAKING QUANTUM TO INDUSTRY

Looking to life after graduate research, Cameron is clear that he wants get into the business side of science and he’s excited by the startup world. “I always wanted to be a businessperson,” he revealed. “I always looked up to physicists who became consultants because they collect information that matters and turn it into something someone else can use.”

Cameron aspires to be part of an ecosystem that enables the commercialization of research. He sees his PhD as a stepping stone towards this goal, giving him crucial insight and credibility. Being in Waterloo has inspired him to think seriously about entrepreneurship. In 2018, Cameron took time out from his graduate study to co-found his first startup.

Cameron has found the ideal launch pad at IQC where he values the diversity of people and ideas above all else.

“That’s how everything should be,” he said. “You should have people of all different backgrounds coming together.”

He also recommends diversifying personal experience as a way of gaining practical and transferable skills for post-graduation life.

Back from concentrating on his startup and boosted by the Vanier Scholarship, Cameron’s priority is his research. He’s still involved with his business, but he’s a scientist first and foremost: “it’s just good to be here doing science.” ■

Around the INSTITUTE

Taking quantum key distribution out of the lab

Members of **THOMAS JENNEWEIN's** Quantum Photonics research group designed a free-space demonstrator of quantum key distribution (QKD) and showcased it to the IQC community on October 17. Research associate **KATANYA KUNTZ**, IQC students **SEBASTIAN SLAMAN** and **RAMY TANNOUS**, and undergraduate research assistant **LINDSAY BABCOCK** built the demo using specialized hardware components from industry partner Excelitas. The demo is portable and performs QKD, the generation of an encrypted key shared between two parties, Alice and Bob, using the properties of quantum physics to guarantee its security. Excelitas is using the portable demo to showcase its hardware at trade shows and conferences.

WATCH ONLINE

<http://bit.ly/QKD-out-of-the-lab> ■

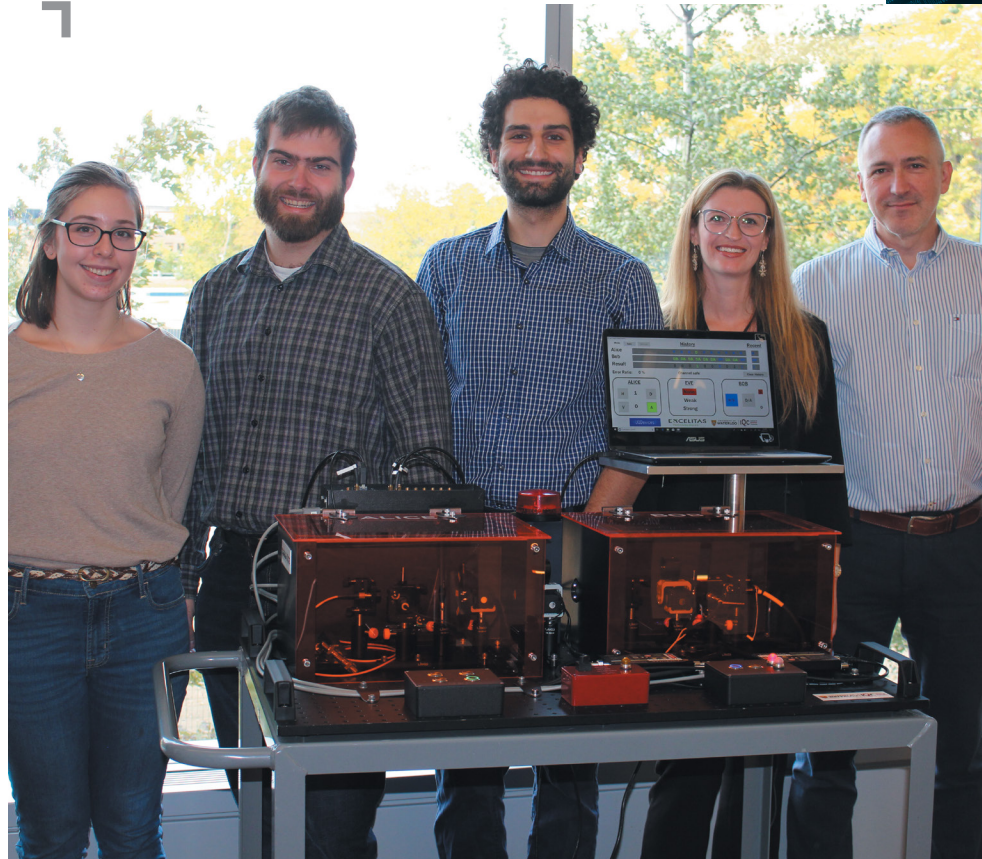

Month-by-month replay from the IQC GSA

The IQC GSA continued to run a full calendar of social activities designed to bring together students and the IQC community. In September, the GSA hosted a lunchtime barbecue for all members and organized a group outing to Canada's Wonderland. There was some serious Halloween fun at the October monthly gathering, which saw **CHRISTINE DIETRICH** and **GREG HOLLOWAY** winning prizes in the GSA best costume contest. Regretfully, any photos taken that evening were too terrifying to publish. November saw the return of the GSA's popular board game night, and the beginning of the winter holidays was marked by a University of Waterloo interdepartmental social, co-hosted by the IQC GSA. ■

IN THE NEWS



Why Canada Will Win the Quantum Race

“Canada’s “quantum valley” is poised to win [the quantum race] - they have a 16 year advantage in building and commercializing the technology, private and government support, an influx of scientific talent, and an exploding startup scene,” predicted **NATALIE FRATTO** in an October issue of Hackernoon. Fratto, Silicon Valley Bank’s early stage practice vice-president, cited founding director **RAYMOND LAFLAMME**’s view that the 2002 launch of IQC “fired the starting gun,” with the investment by visionary **MIKE LAZARIDIS** and the Canadian and Ontario governments as key in building “the infrastructure and resources needed for quantum dominance.”

WEB bit.ly/canada-win-quantum-race ■

ACTIVITIES



IQC alumni **CHRIS FERRIE** and **MARTIN LAFOREST** were on hand for the opening weekend at the Ontario Science Centre, talking quantum over coffee with guests.

Toronto experiences *QUANTUM: The Exhibition*

Over 290,000 visitors explored the world of quantum during the five-month run of **QUANTUM: The Exhibition** at the Ontario Science Centre in Toronto from August to January.

“Our goal in developing *QUANTUM* was to engage people of all ages in a fun and unique way,” said **ANGELA OLANO**, IQC’s manager, special projects. “We want everyone to have an understanding of how quantum technologies will change

their lives.” *QUANTUM* offers interactive activities, games and videos to introduce visitors to the worlds of quantum mechanics and information technology, and learn how they are converging to shape the technologies of the future. To date, almost 685,000 visitors have experienced *QUANTUM: The Exhibition*. ■

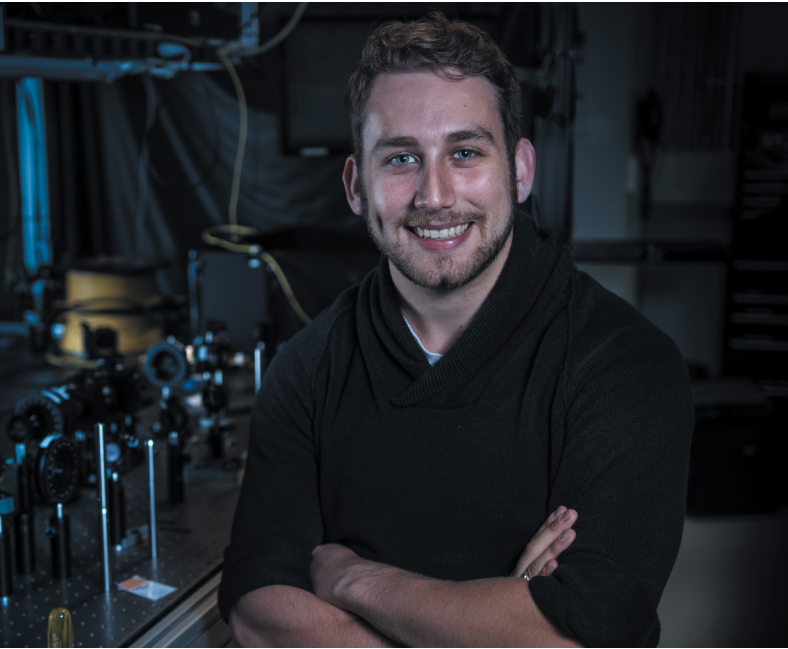

IQC graduate student wins prestigious Vanier scholarship

ANDREW CAMERON, a first-year PhD candidate in the Department of Physics and Astronomy, was awarded the Vanier Canada Graduate scholarship to pursue quantum optics research at IQC. This prestigious graduate award is worth \$50,000 per year for three years. Cameron's research is conducted under the supervision of IQC interim executive director **KEVIN RESCH**.

WEB bit.ly/cameron-vanier-scholarship ■

Quantum startup launches new software system



Quantum Benchmark, a spin-off company of research performed at IQC, launched a suite of software products for users and makers of quantum computers. The True-Q™ software system, announced in July, optimizes hardware design and quantum computing performance through error characterization, error suppression, error correction and performance validation.

Co-founded by faculty member **JOSEPH EMERSON** and research assistant professor **JOEL WALLMAN**, Quantum Benchmark was recognized as a “top startup” by IBM. The scientific team of researchers include IQC PhD students **KRISTINE BOONE** and **ARNAUD CARIGNAN-DUGAS**, along with Master's student **JARON HUQ**.

WEB bit.ly/quantum-benchmark ■

ANNOUNCEMENTS AND AWARDS

Boost for international collaborations

WEI TSEN and **ROBERT MANN** received International Research Partnership Grants from the Office of Research at the University of Waterloo. The grants are intended to further Waterloo researchers' global collaborations with leading institutions.

Tsen, IQC faculty member and assistant professor in the Department of Chemistry, is partnering with Pohang University of Science and Technology in Korea to research and develop wafer-scale 2D magnetic heterostructures for next-generation spintronic devices.

Mann, IQC associate and professor in the Department of Physics and Astronomy, is working with the University of Vienna to develop novel experiments to test the quantum nature of gravitational force, and explore the relationship between gravity and quantum physics to come to a better understanding of gravity as more than "just a force."

WEB bit.ly/intl-research-partnership ■



SHAYAN MAJIDY

JEREMY FLANNERY

Recognizing community outreach and engagement

Two IQC graduate students, **SHAYAN MAJIDY** and **JEREMY FLANNERY**, were awarded the David Johnston Scientific Outreach award, recognizing their dedication to promoting public awareness of quantum research and science in the community.

At IQC and on the road, Master's student Majidy gives lectures and runs hands-on workshops about quantum cryptography for high school students.

PhD student Flannery is involved with outreach as a workshop facilitator, and has connected with a broader audience to explain the importance of fundamental research and the future impact of quantum technologies as a tour guide for *QUANTUM: The Pop-Up Exhibition*. ■



CHRISTOPHER CHAMBERLAND

Excellence in research achievement

PhD student **CHRISTOPHER CHAMBERLAND** received the IQC Achievement Award for his work in flag fault-tolerant error correction with arbitrary distance codes. Flag fault-tolerant error correction can be useful for early fault-tolerant experiments since these methods use fewer qubits than any other fault-tolerant protocol. After successfully defending his thesis, Chamberland accepted a research staff position at the IBM T.J. Watson Research Center quantum group. ■



COURSES

SPRING 2018

QIC 890

Intro to Noise Processes

QIC 891

Topics in Quantum Information

FALL 2018

QIC 710

Quantum Information Processing

QIC 890

Modern Quantum Optics and Nanophotonics

QIC 890

Quantum Optics

QIC 890

Quantum Sensing



THESIS DEFENCES

Congratulations to everyone who defended their thesis, including:

MATTHEW AMY, PhD

STEFANIE BEALE, Master's

CHRISTOPHER CHAMBERLAND, PhD

OLIVIA DI MATTEO, PhD

AIMEE GUNTHER, PhD

IAN HINCKS, PhD

EMMA MCKAY, Master's

SATISH PANDEY, PhD

JITENDRA PRAKASH, PhD

DANIEL PUZZUOLI, PhD

RAMY TANNOUS, Master's

CHUNHAO WANG, PhD



Students

Xi Dai
Jack Davis
Marcus Edwards
Ryan Ferguson
Thomas Fraser
Ian George
Soumik Ghosh
Noah Greenberg
Melissa Henderson
Shih-Chun (Jimmy) Hung
Rabiul Islam
Aditya Jain
Chi Hang (Angus) Kan
Connor Kapahi
Michal Kononenko
Kai Hong (Nicky) Li
Lin Sheng-Xiang
Mary Katherine MacPherson
AJ Malcolm
Julia Maristany
Irene Melgarejo Leimas
Olivier Nahman-Levesque
Daniel Paulson
Kevin Piche
Manas Sajjan
Austin Woolverton

Postdoctoral fellows

Yasar Atas
Salil Bedkihal
Divya Bharadwaj
Matthew Day
Luca Dellantonio
Jan Friedrich Haase
Aaron Hutchinson
Pavithran Sridharan Iyer
Peng Li
Mona Mirzaeimoghri
Travis Morrison
Priyanka Mukhopadhyay

Staff

John Donohue
Shoshannah Holdom
Kaitlyn McDonell
Alexis Nagum
Lana Spletstoesser
Andrew Turski

Visitors

Ruipeng Li
Hao Zeng
Weijie Wu
Tal Mor
Daniel Grier
Pei Zeng
Zhihao Song
Yingcheng Li
Yidun Wan
Bojia Duan
Layla Hormozi
Arpita Maitra
Nadish de Silva
Yu-Bo Sheng
Lan Zhou



Quantum Cryptography
School for Young Students

By the numbers: 2018 Quantum Cryptography School for Young Students (QCSYS)



242
applications



44
participants from
around the globe including:



50%
women



50%
men

Canada	31
United States	6
Greece	2
India	1
Pakistan	1
Poland	1
Singapore	1
United Kingdom	1



36.5
hours of lectures



6
hours of experiments



4
hours of mentoring
sessions



3.5
hours of group work



50
total hours
immersed in the
quantum world



Quantum Key Distribution
Summer School

August 19-23, 2019

Explore Quantum Key Distribution

Institute for Quantum Computing, University of Waterloo

Gain a solid foundation of quantum key distribution (QKD) taught by international leaders in the field at QKD Summer School.

The five-day program for graduate students and young postdoctoral fellows focuses on the theoretical and experimental aspects of quantum communication. QKD experts will cover topics including classical cryptography, security analysis and optical implementation of QKD, and QKD in a cryptoworld.

- Learn independent research techniques in quantum communication
- Connect with other young QKD researchers from around the world
- Learn about modern perspectives

Apply by June 3, 2019: uwaterloo.ca/iqc/qkd

A \$250 CAD registration fee is required upon acceptance.



UNIVERSITY OF
WATERLOO



Institute for
Quantum
Computing



Ontario

Canada